

NO	DESCRIPTION	NO	DESCRIPTION
1C	CARGO TANK VALVE	13C	CARGO PIPING BLOCK VALVE
2C	LOAD VALVE	19C	CARGO HEADER
3C	MASTER SUCTION VALVE	30C	CARGO PIPELINE
4C	DISCHARGE VALVE	31C	BYPASS VALVE
5C	HEADER VALVE	37C	CARGO DROP
6C	SALVAGE VALVE	—	— ABOVE DECK PIPING
8C	RELIEF VALVE	---	--- BELOW DECK PIPING
9C	CHECK VALVE		
10C	BURP VALVE		
12C	BURP VALVE RETURN TO CARGO TANK		

NOTE 1: CONTAINMENT P/S  
NOTE 2: RIGGING IS TYPICAL IN EACH TANK

1	08/26/24	AC	DDA	DC	REVISED PER CLIENT COMMENTS	
0	10/26/23	MRV	DDA	WHI	ISSUED FOR APPROVAL	
REV.	DATE	BY	CHK	APP	REVISION DESCRIPTION	

KIRBY INLAND MARINE

CARGO

PIPING FLOW DIAGRAM

SCALE: NONE	PBL 3423	REV.
PAGE: 1 OF 2		1

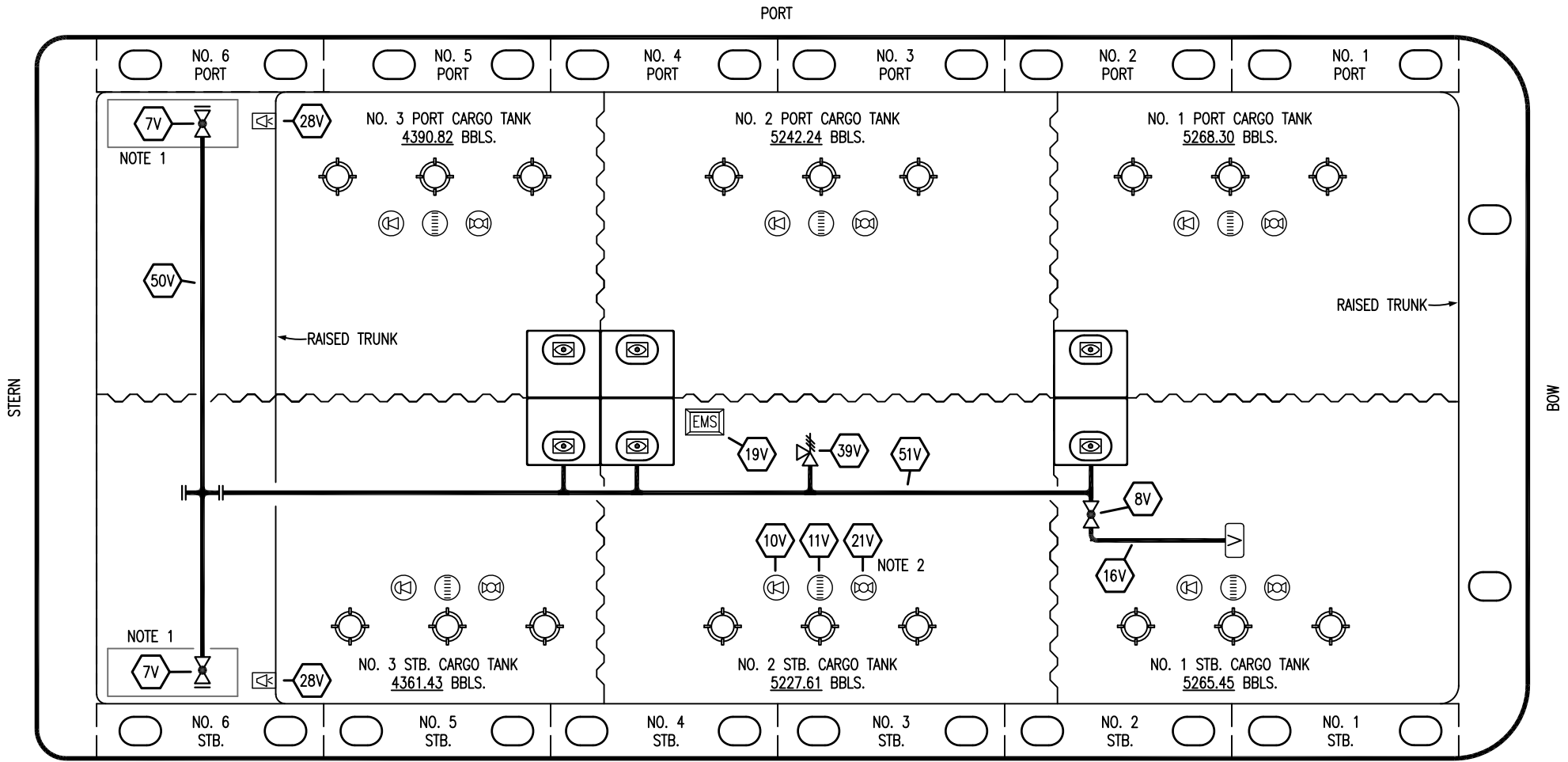

NO	DESCRIPTION	NO	DESCRIPTION
7V	HEADER VALVE	28V	DOCK CONNECTION ALARM
8V	VENT STACK VALVE	38V	VAPOR PENETRATION
10V	HIGH LEVEL/OVERFILL ALARM	39V	PRESSURE/VACUUM VALVE
11V	1-METER GAUGE STICK	50V	VAPOR HEADER
16V	VAPOR VENT STACK	51V	VAPOR PIPELINE
19V	EMERGENCY ENGINE SHUT DOWN	59V	PRESS/VAC GAUGE
21V	HERMETIC GAUGE	—	ABOVE DECK PIPING

NOTE 1: CONTAINMENT P/S  
 NOTE 2: RIGGING IS TYPICAL IN EACH TANK

REV.	DATE	BY	CHK	APP	REVISION DESCRIPTION
1	08/26/24	AC	DDA	DC	REVISED PER CLIENT COMMENTS
0	10/26/23	MRV	DDA	WHI	ISSUED FOR APPROVAL

**KIRBY INLAND MARINE**

**VAPOR  
PIPING FLOW DIAGRAM**

SCALE: NONE	<b>PBL 3423</b>	REV. 1
PAGE: 2 OF 2		