



NO	DESCRIPTION	NO	DESCRIPTION
1C	CARGO TANK VALVE	19C	CARGO HEADER
2C	LOAD VALVE	30C	CARGO PIPELINE
3C	MASTER SUCTION VALVE	31C	BYPASS VALVE
4C	DISCHARGE VALVE	37C	CARGO DROP 
5C	HEADER VALVE	—	— ABOVE DECK PIPING
8C	RELIEF VALVE	---	--- BELOW DECK PIPING
9C	CHECK VALVE		
10C	BURP VALVE		

NOTE 1: CONTAINMENT P/S

TRINITY MARINE -- EX. WTC 3016-3019

REV.	DATE	BY	CHK	APP	REVISION DESCRIPTION
2	06/26/23	MRV	DDA	DAR	REVISED PER CLIENT COMMENTS
1	07/12/18	WFB	DDA		REVISED PER CLIENT COMMENTS
0	11/16/16	WFB	DDA		ISSUED FOR APPROVAL

KIRBY INLAND MARINE 

CARGO

PIPING FLOW DIAGRAM

KIRBY 30085

REV. 2

SCALE: NONE
PAGE: 1 OF 3

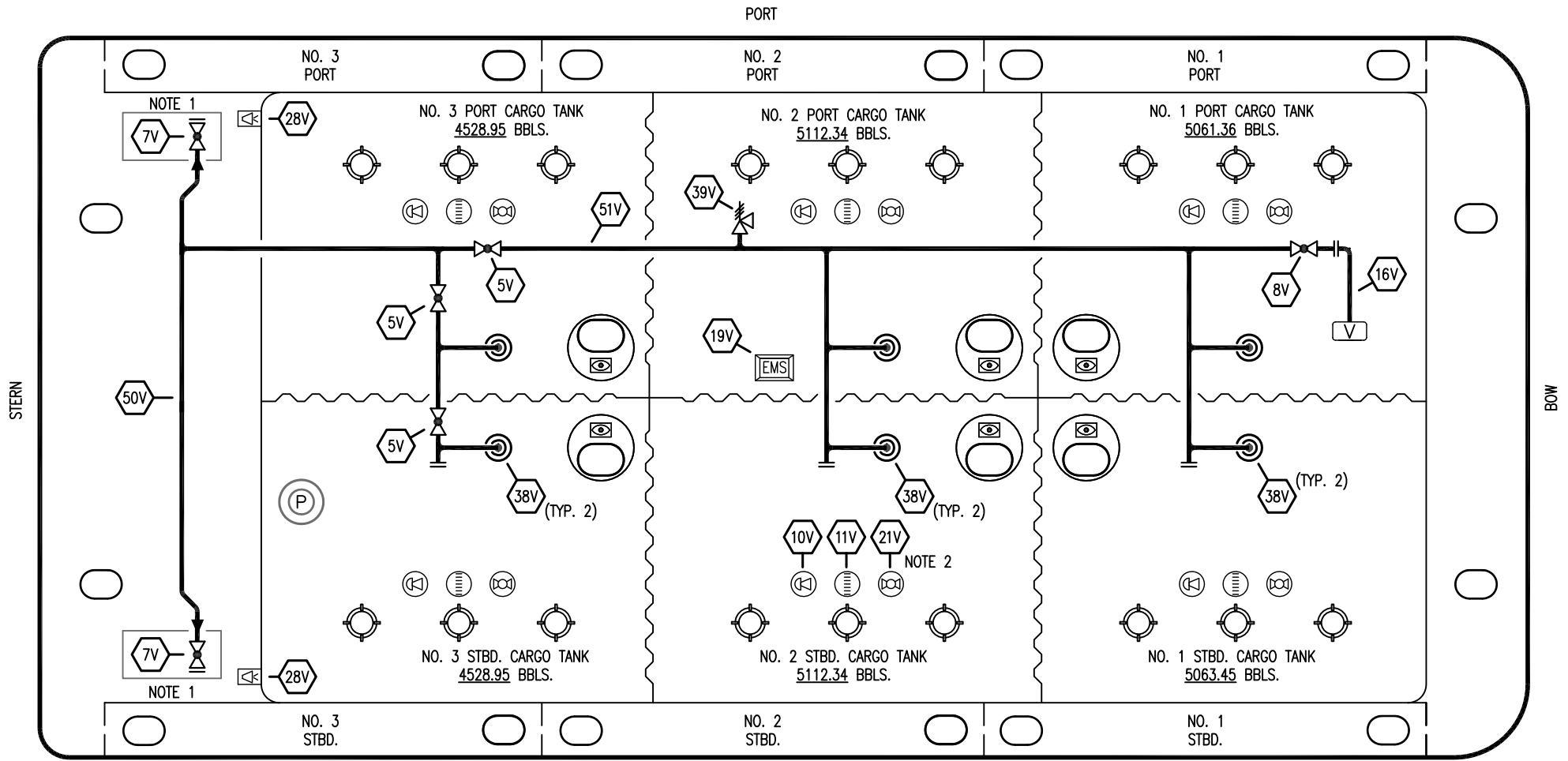

NO	DESCRIPTION	NO	DESCRIPTION
5V	BLOCK VALVE	28V	DOCK CONNECTION ALARM
7V	HEADER VALVE	38V	VAPOR DROP OR PENETRATION
8V	VENT STACK VALVE	39V	PRESSURE/VACUUM RELIEF VALVE
10V	HIGH LEVEL/OVERFILL ALARM	50V	VAPOR HEADER
11V	GAUGE STICK	51V	VAPOR PIPELINE
16V	VAPOR VENT STACK	—	— ABOVE DECK PIPING
19V	EMERGENCY SHUT DOWN	- - -	- - - BELOW DECK PIPING
21V	HERMETIC GAUGE		

NOTE 2: TYPICAL RIGGING IN EACH TANK
 NOTE 1: CONTAINMENT P/S

TRINITY MARINE — EX. WTC 3016—3019

REV.	DATE	BY	CHK	APP	REVISION DESCRIPTION
2	06/26/23	MRV	DDA	DAR	REVISED PER CLIENT COMMENTS
1	07/12/18	WFB	DDA		REVISED PER CLIENT COMMENTS
0	11/16/16	WFB	DDA		ISSUED FOR APPROVAL

KIRBY INLAND MARINE

VAPOR
PIPING FLOW DIAGRAM

SCALE: NONE	KIRBY 30085	REV.
PAGE: 2 OF 3		REV. 2

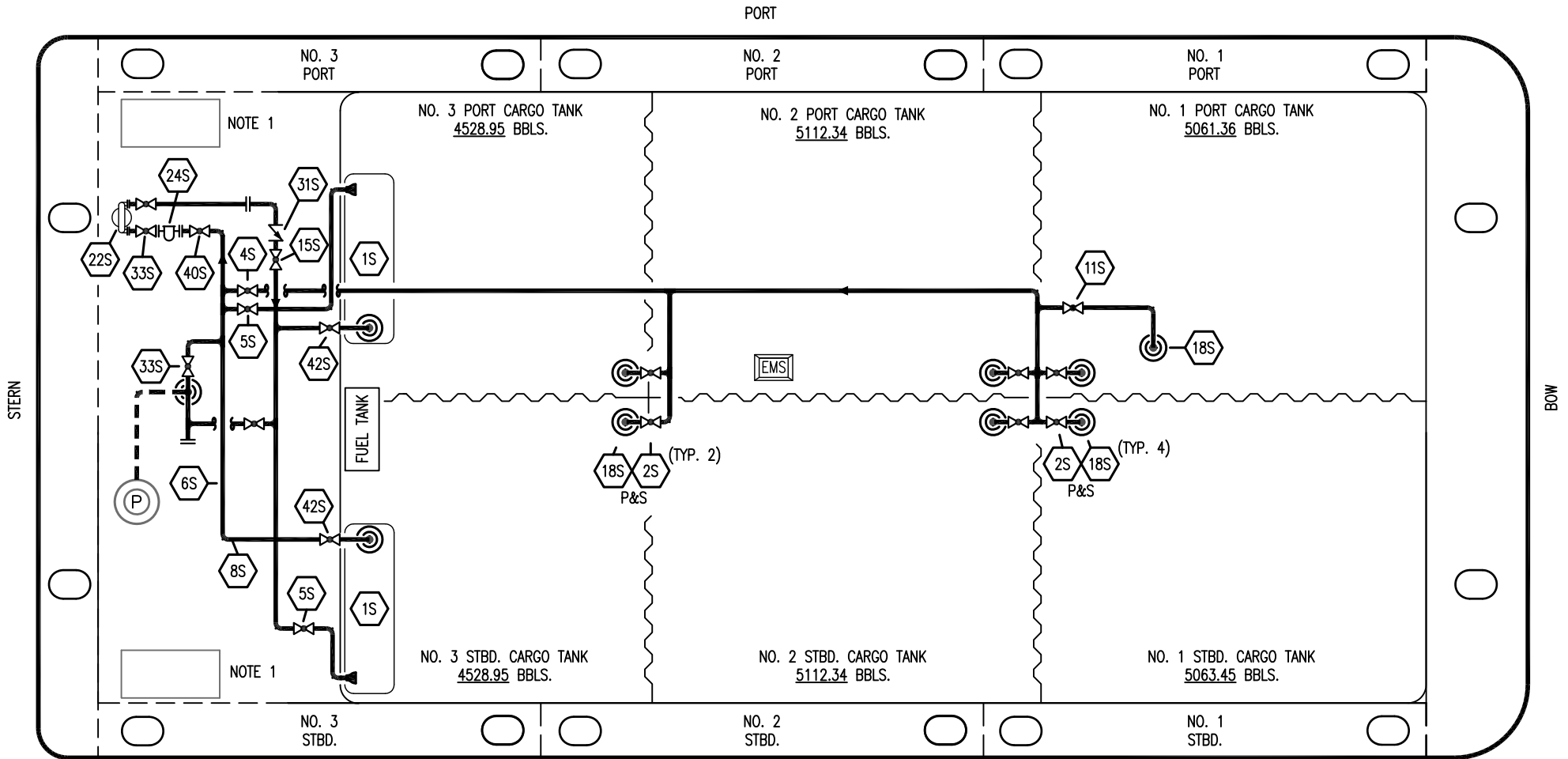

- | | | | |
|-----------|--------------------------|-----------|-------------------------|
| NO | DESCRIPTION | NO | DESCRIPTION |
| 1S | SLOP TANK | 31S | CHECK VALVE |
| 2S | CARGO SUMP SUCTION VALVE | 33S | PUMP WELL SUCTION VALVE |
| 5S | SLOP TANK SUCTION VALVE | 37S | BLOCK VALVE |
| 6S | SUCTION HEADER PIPING | 40S | HEADER SUCTION VALVE |
| 8S | DISCHARGE HEADER PIPING | 42S | SLOP TANK FILL VALVE |
| 15S | HEADER DISCHARGE VALVE | — | — |
| 18S | STRIPPING DROP | — | — |
| 22S | STRIPPING PUMP | — | — |
| 24S | BASKET STRAINER | — | — |

STARBOARD

NOTE 1: CONTAINMENT P/S

- ABOVE DECK PIPING
 - - - BELOW DECK PIPING

TRINITY MARINE – EX. WTC 3016–3019

KIRBY INLAND MARINE 

**STRIPPING
 PIPING FLOW DIAGRAM**

REV.	DATE	BY	CHK	APP	REVISION DESCRIPTION
2	06/26/23	MRV	DDA	DAR	REVISED PER CLIENT COMMENTS
1	07/12/18	WFB	DDA		REVISED PER CLIENT COMMENTS
0	11/16/16	WFB	DDA		ISSUED FOR APPROVAL

SCALE: NONE
 PAGE: 3 OF 3

KIRBY 30085

REV. **2**