

PORT

STERN

BOW

STARBOARD

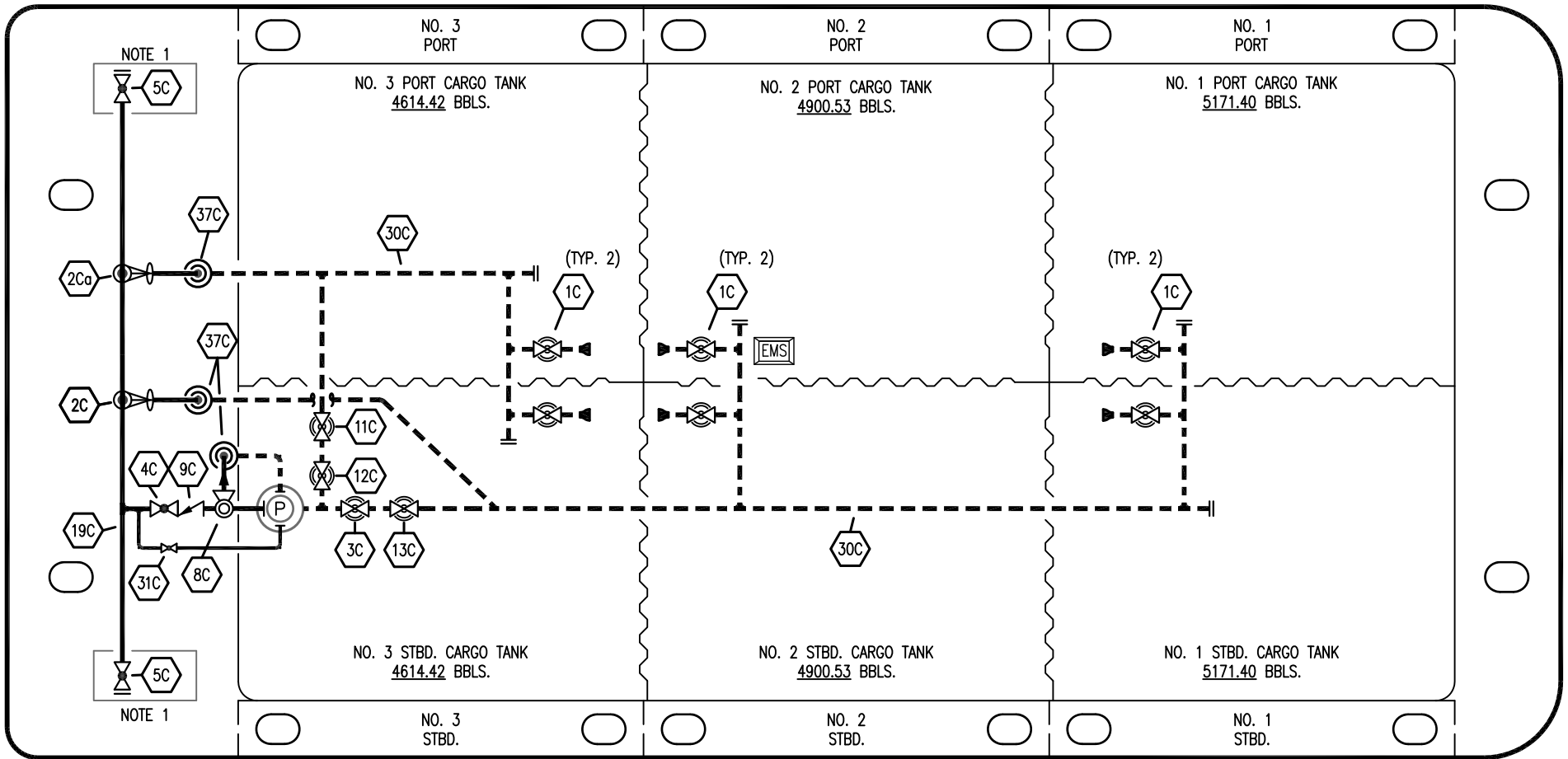

NOTE 1

NOTE 1

NO	DESCRIPTION	NO	DESCRIPTION
1C	CARGO TANK VALVE	11C	#2 C/T BLOCK VALVE
2C	#1 C/T LOAD VALVE	12C	#2 C/T SUCTION VALVE
2Ca	#2 C/T LOAD VALVE	13C	#1 C/T MASTER SUCTION VALVE
3C	#1 C/T SUCTION VALVE	19C	CARGO HEADER
4C	DISCHARGE VALVE	30C	CARGO PIPELINE
5C	HEADER VALVE	31C	BYPASS VALVE
8C	RELIEF VALVE	37C	CARGO DROP
9C	CHECK VALVE	—	— ABOVE DECK PIPING
		- - -	BELOW DECK PIPING

NOTE 1: CONTAINMENT P/S

TRINITY MARINE — EX. WTC 3011

REV.	DATE	BY	CHK	APP	REVISION DESCRIPTION
3	08/24/23	MRV	DDA	KW	REVISED PER CLIENT COMMENTS
2	03/03/20	MRV	DDA		REVISED PER CLIENT COMMENTS
1	07/09/18	WFB	DDA		REVISED PER CLIENT COMMENTS
0	11/16/16	WFB	DDA		ISSUED FOR APPROVAL

KIRBY INLAND MARINE

**CARGO
PIPING FLOW DIAGRAM**

SCALE: NONE
PAGE: 1 OF 3

KIRBY 30080

REV. **3**

PORT

STERN

BOW

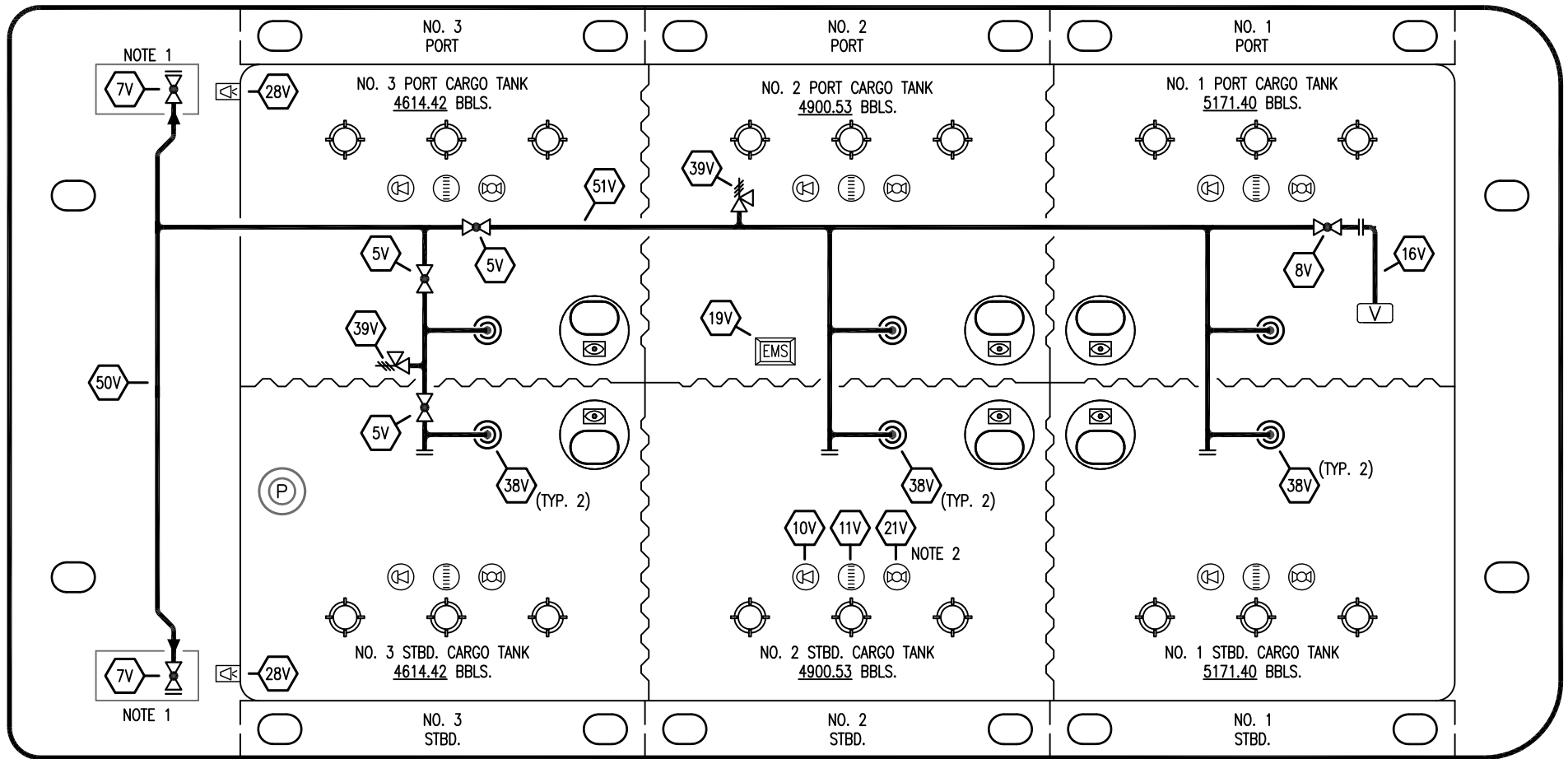

STARBOARD

NO	DESCRIPTION	NO	DESCRIPTION
5V	BLOCK VALVE	28V	DOCK CONNECTION ALARM
7V	HEADER VALVE	38V	VAPOR DROP OR PENETRATION
8V	VENT STACK VALVE	39V	PRESSURE/VACUUM RELIEF VALVE
10V	HIGH LEVEL/OVERFILL ALARM	50V	VAPOR HEADER
11V	GAUGE STICK	51V	VAPOR PIPELINE
16V	VAPOR VENT STACK	—	ABOVE DECK PIPING
19V	EMERGENCY SHUT DOWN	---	BELOW DECK PIPING
21V	HERMETIC GAUGE		

NOTE 2: TYPICAL RIGGING IN EACH TANK

NOTE 1: CONTAINMENT P/S

TRINITY MARINE – EX. WTC 3011

KIRBY INLAND MARINE 

**VAPOR
PIPING FLOW DIAGRAM**

REV.	DATE	BY	CHK	APP	REVISION DESCRIPTION
2	08/24/23	MRV	DDA	KW	REVISED PER CLIENT COMMENTS
1	07/09/18	WFB	DDA		REVISED PER CLIENT COMMENTS
0	11/16/16	WFB	DDA		ISSUED FOR APPROVAL

SCALE: NONE
PAGE: 2 OF 3

KIRBY 30080

REV. **2**

PORT

STERN

BOW

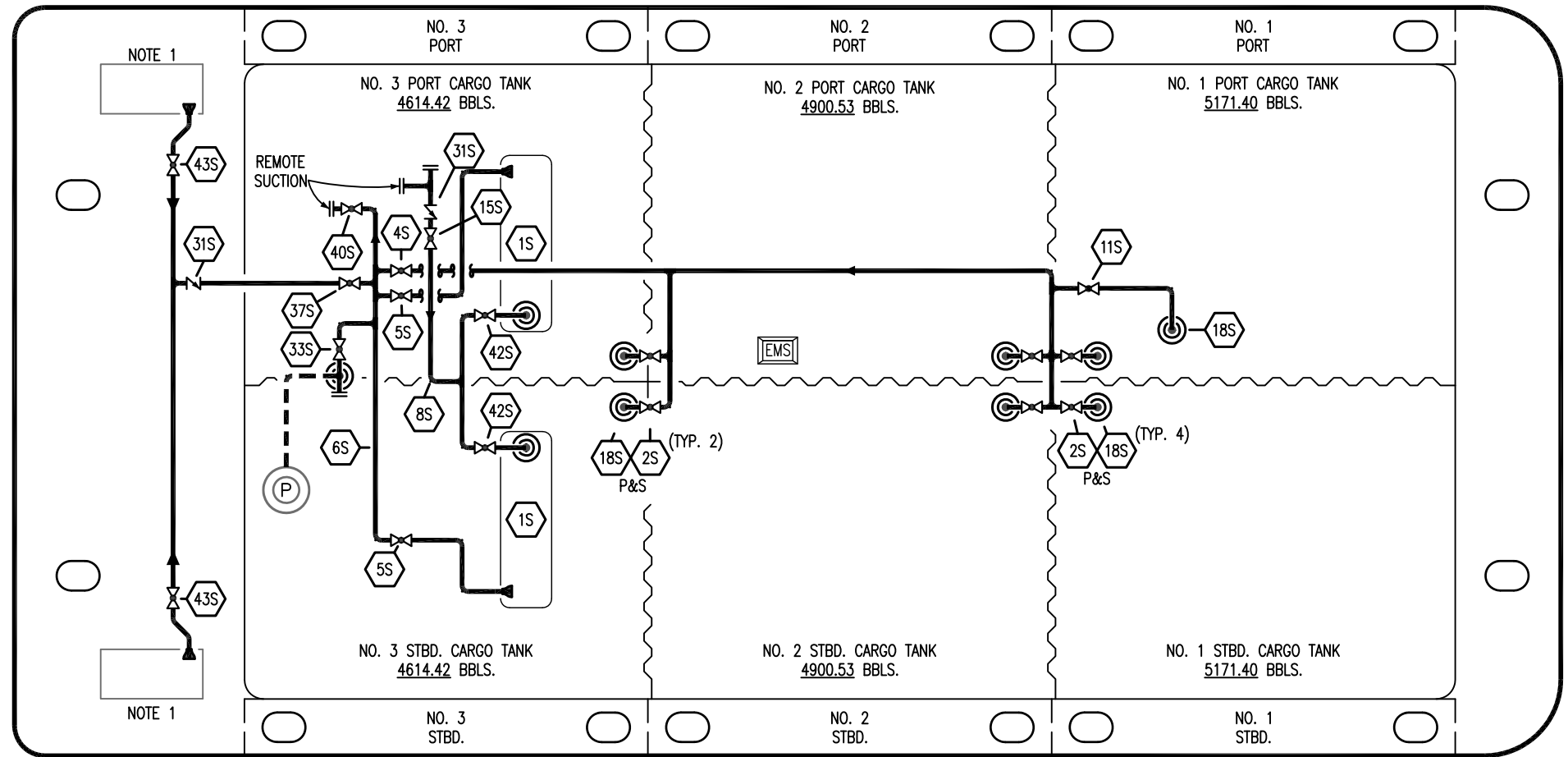

NO	DESCRIPTION	NO	DESCRIPTION
1S	SLOP TANK	31S	CHECK VALVE
2S	CARGO SUMP SUCTION VALVE	33S	PUMP WELL SUCTION VALVE
5S	SLOP TANK SUCTION VALVE	37S	BLOCK VALVE
6S	SUCTION HEADER PIPING	40S	HEADER SUCTION VALVE
8S	DISCHARGE HEADER PIPING	42S	SLOP TANK FILL VALVE
15S	HEADER DISCHARGE VALVE	43S	DRIP PAN SUCTION VALVE
18S	STRIPPING DROP		— ABOVE DECK PIPING
			- - - BELOW DECK PIPING

STARBOARD

NOTE 1: CONTAINMENT P/S

TRINITY MARINE – EX. WTC 3011

REV.	DATE	BY	CHK	APP	REVISION DESCRIPTION
2	08/24/23	MRV	DDA	KW	REVISED PER CLIENT COMMENTS
1	07/09/18	WFB	DDA		REVISED PER CLIENT COMMENTS
0	11/16/16	WFB	DDA		ISSUED FOR APPROVAL

KIRBY INLAND MARINE 

**STRIPPING
PIPING FLOW DIAGRAM**

SCALE: NONE
PAGE: 3 OF 3

KIRBY 30080

REV. **2**