

PORT

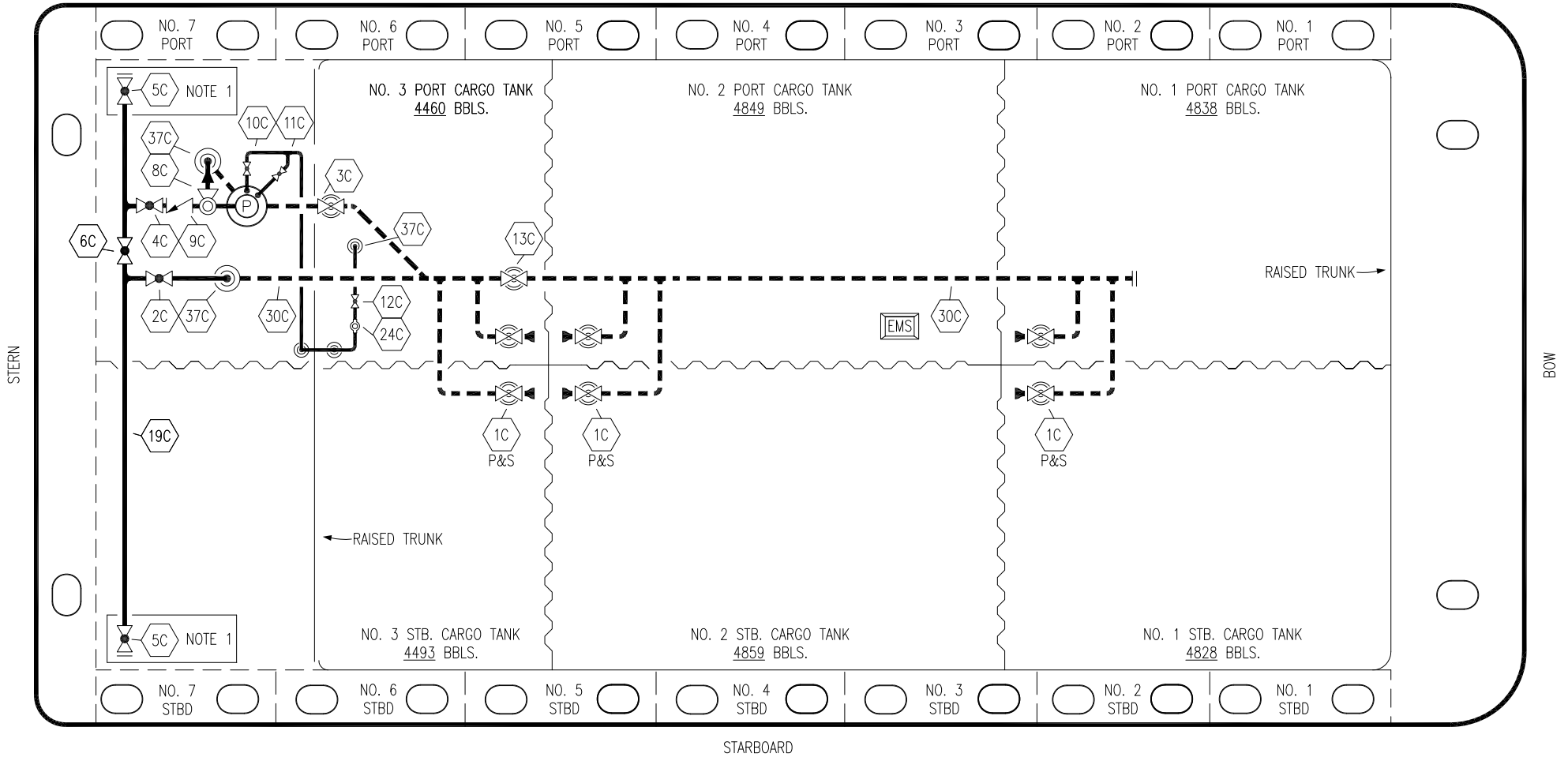

- | | | | |
|-----|----------------------|-------|---------------------------------|
| NO | DESCRIPTION | NO | DESCRIPTION |
| 1C | CARGO TANK VALVE | 12C | BURP VALVE RETURN TO CARGO TANK |
| 2C | LOAD VALVE | 13C | CARGO PIPING BLOCK VALVE |
| 3C | MASTER SUCTION VALVE | 19C | CARGO HEADER |
| 4C | DISCHARGE VALVE | 24C | FLOW INDICATOR |
| 5C | HEADER VALVE | 30C | CARGO PIPELINE |
| 6C | SALVAGE VALVE | 37C | CARGO DROP |
| 8C | RELIEF VALVE | | |
| 9C | CHECK VALVE | — | ABOVE DECK PIPING |
| 10C | BURP VALVE | - - - | BELOW DECK PIPING |
| 11C | BLEED OFF VALVE | | |

NOTE 1: CONTAINMENT P/S

REV.	DATE	BY	CHK	APP	REVISION DESCRIPTION
1	12/03/14	DDA	DDA		REVISED PER CLIENT COMMENTS
0	06/18/14	DDA	DDA		ISSUED FOR APPROVAL

TRINITY

KIRBY INLAND MARINE

CARGO

PIPING FLOW DIAGRAM

SCALE: NONE	KIRBY 29121
PAGE: 1 OF 3	REV. 1

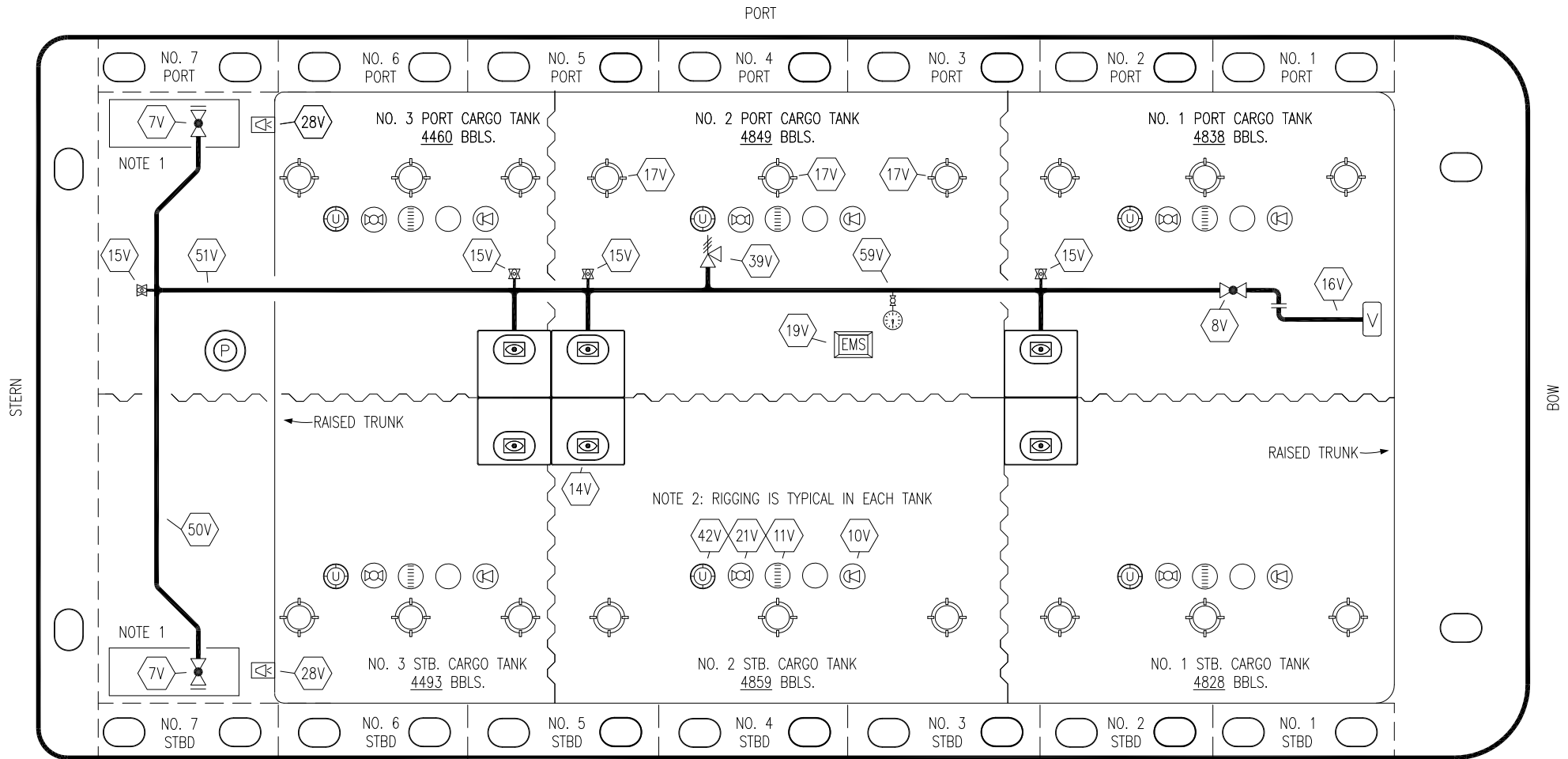

NO	DESCRIPTION	NO	DESCRIPTION
7V	8" HEADER VALVE	21V	2" HERMETIC GAUGE
8V	8" VENT STACK VALVE	27V	1/4" TEST CONNECTION VALVE
10V	8" HIGH LEVEL/OVERFILL ALARM	28V	DOCK CONNECTION ALARM
11V	8" 1-METER STICK GAUGE	38V	8" VAPOR PENETRATION
14V	6" SIGHT GLASS W/GAUGE TREE	39V	PRESS/VAC RELIEF VALVE
15V	2" INSPECTION PORT	42V	8" ULLAGE HATCH
16V	8" VAPOR VENT STACK	50V	8" VAPOR HEADER
17V	14" BUTTERWORTH	51V	8" VAPOR PIPELINE
18V	2" RESTRICTIVE GAUGE TUBE	59V	PRESS/VAC GAUGE
19V	EMERGENCY ENGINE SHUT DOWN	—	— ABOVE DECK PIPING

NOTE 1: CONTAINMENT P/S
 NOTE 2: RIGGING IS TYPICAL IN EACH TANK

REV.	DATE	BY	CHK	APP	REVISION DESCRIPTION
1	12/03/14	DDA	DDA		REVISED PER CLIENT COMMENTS
0	06/18/14	DDA	DDA		ISSUED FOR APPROVAL

TRINITY

KIRBY INLAND MARINE

**VAPOR
PIPING FLOW DIAGRAM**

SCALE: NONE	KIRBY 29121
PAGE: 2 OF 3	REV. 1

PORT

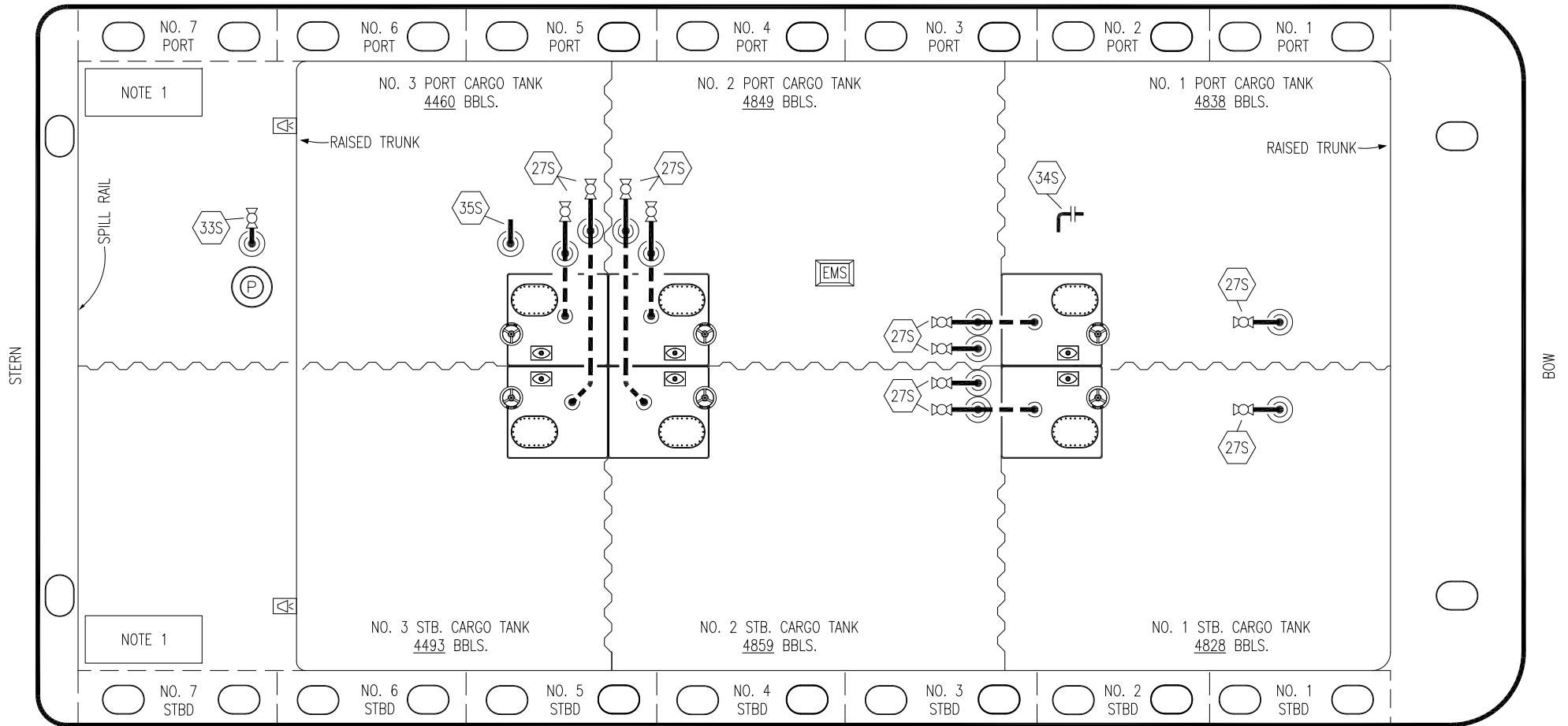

- | | |
|-----|---------------------------|
| NO | DESCRIPTION |
| 18S | TYP. STRIPPING DROP |
| 27S | SUMP SUCTION VALVE |
| 32S | PUMP WELL PRIMER VALVE |
| 33S | 2" SUCTION FOR DEEPWELL |
| 34S | 4" FLANGED STUBOUT |
| 35S | 2" STRIPPING FOR PIPELINE |
| | ABOVE DECK PIPING |
| | BELOW DECK PIPING |

NOTE 1: CONTAINMENT P/S

TRINITY

1	12/03/14	DDA	DDA		REVISED PER CLIENT COMMENTS
0	06/18/14	DDA	DDA		ISSUED FOR APPROVAL
REV.	DATE	BY	CHK	APP	REVISION DESCRIPTION

KIRBY INLAND MARINE

**STRIPPING
PIPING FLOW DIAGRAM**

SCALE: NONE	KIRBY 29121	REV. 1
PAGE: 3 OF 3		