

PORT

BOW

STERN

STARBOARD

TRINITY MARINE



KIRBY INLAND MARINE

CARGO

PIPING DIAGRAM

REV. 2

KIRBY 29098

SCALE: NONE
PAGE: 1 OF 3

NOTE 1: CONTAINMENT P/S
NOTE 2: SALVAGE LINE TO PUMP SUCTION

- NO. DESCRIPTION
- 1C CARGO TANK VALVE
 - 2C LOAD VALVE
 - 3C MASTER SUCTION VALVE
 - 4C DISCHARGE VALVE
 - 5C HEADER VALVE
 - 13C CARGO PIPING BLOCK VALVE
 - 19C CARGO HEADER
 - 30C CARGO PIPELINE
 - 37C CARGO DROP
- ABOVE DECK PIPING
- - - BELOW DECK PIPING

REV.	DATE	BY	CHK	APP	REVISION DESCRIPTION
2	12/21/16	WFB	DDA		REVISED PER CLIENT COMMENTS
1	06/12/14	DDA	DDA	OF	REVISED PER CLIENT COMMENTS
0	03/21/14	GP	GP	OF	ISSUED FOR APPROVAL

PORT

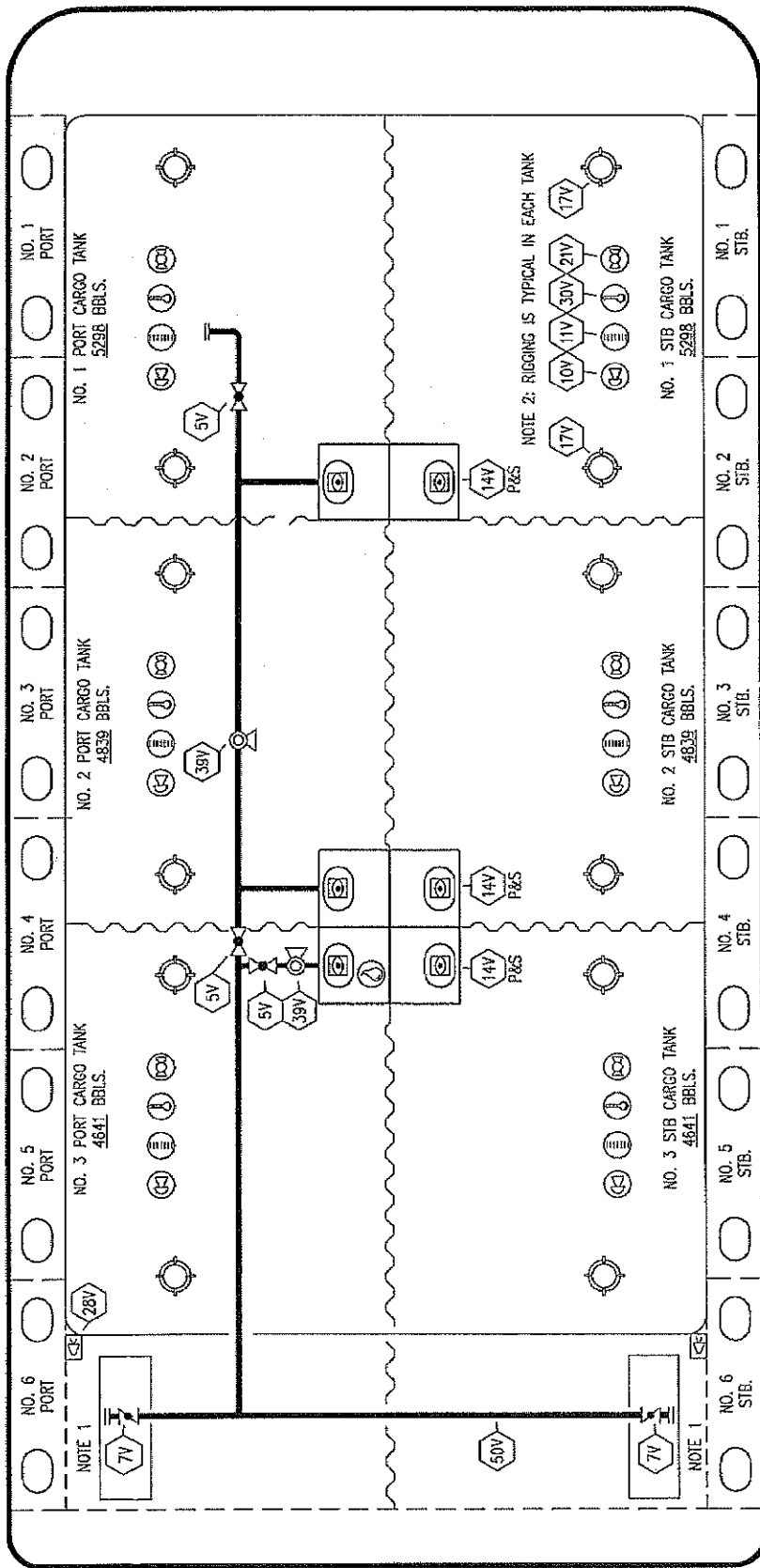

STERN

BOW

NOTE 2: RIGGING IS TYPICAL IN EACH TANK

NOTE 2: RIGGING IS TYPICAL IN EACH TANK

NOTE 2: RIGGING IS TYPICAL IN EACH TANK

NOTE 2: RIGGING IS TYPICAL IN EACH TANK

STARBOARD

DESCRIPTION

- 5V BLOCK VALVE
- 7V 8" HEADER VALVE
- 10V 8" HIGH LEVEL/OVERFILL ALARM
- 11V 8" 1-METER STICK GAUGE
- 14V 8" SIGHT GLASS W/GAUGE TREE
- 17V 19" BUTTERWORTH
- 21V 2" HERMETIC GAUGE
- 28V DOCK CONNECTION ALARM
- 39V PRESSURE/VACUUM VALVE
- 50V 8" VAPOR HEADER
- 51V 8" VAPOR PIPELINE

NOTE 1: CONTAINMENT P/S
NOTE 2: RIGGING IS TYPICAL IN EACH TANK

TRINITY SHIPYARD

KIRBY INLAND MARINE

VAPOR

PIPING DIAGRAM

KIRBY 29098

REV	DATE	BY	CHK APP	REVISION DESCRIPTION
1	06/12/14	DDA	DDA	REVISED PER CLIENT COMMENTS
0	03/21/14	GP	GP	ISSUED FOR APPROVAL

SCALE:	NONE
PAGE:	2 OF 3

REV. **1**

