

KIRBY INLAND MARINE

CARGO TRANSFER PROCEDURES FOR THE BARGE

KIRBY 29066

PLEASE NOTE:

FOR PROPER VALVE ALIGNMENT AND SAFE CARGO TRANSFER GUIDANCE, PLEASE REFER TO KIRBY MARINE TRANSPORTATION'S CARGO HANDLING PROCEDURE MANUAL AND FOLLOW THE KIRBY TRANSFER PLAN.

IF YOU NEED A COPY OF THE PROCEDURE MANUAL, PLEASE CALL THE KIRBY DUTY LINE (713) 435-1618 OR (713) 435-1925 BEFORE CARGO OPERATION.

TABLE OF CONTENTS

SECTION#	TITLE	PAGE
155.750(a)(1):	Cargo Information	4
	I. Proper Shipping Names and Regulatory Compliance	4
	II. Hazard Information Systems and Sources	5
155.750(a)(2):	Barge Transfer System	7
	I. Piping Diagrams	8
	II. Procedures for Emptying Discharge Containment	10
155.750(a)(3):	Persons on Duty During Transfer Operations	11
155.750(a)(4):	Duties of Tankerman (Person in Charge)	12
155.750(a)(5):	Tending Vessel Moorings During Transfer	16
155.750(a)(6):	Procedures for Operating the Emergency Shutdown and Provision of Communications	17
	I. Emergency Shutdown Operations	17
	II. Communications	18
155.750(a)(7):	Procedures for Topping Off Tanks	19
155.750(a)(8):	Procedures for Ensuring All Valves Are Closed	21
155.750(a)(9):	Procedures for Reporting Discharges of Oil and Hazardous Materials	22
155.750(a)(10):	Procedures for Closing and Opening the Vessel Openings	23
155.750(a)(11):	Cargo Hoses Carried on Barges	24

TABLE OF CONTENTS: (cont'd)

SECTION#	TITLE	PAGE
155.750(d)(1):	Vapor System Piping & Arrangement Diagram	25
155.750(d)(2):	Location of Spill Valves or Rupture Disks	27
155.750(d)(3):	Determination of Maximum Allowable Transfer Rate (includes example calculation using worksheets)	28
155.750(d)(4):	Initial Transfer Rate for Each Cargo Tank	32
155.750(d)(5):	Pressure Drop Tables Table I, II, III, IV	34
155.750(d)(6):	PV Valve, Spill Valve, and Rupture Disk Settings	37
155.750(d)(7):	Vapor Control System Operation & Procedures	38
	I. Pre-Transfer Equipment Inspection Requirements	38
	II. Vapor Line Connection	40
	III. Transfer Procedures	41
	IV. Closed Gauging System	41
	V. High Level Alarm System / Automation Shutdown	41
	VI. Post Transfer/Vapor Line Disconnection Procedures	42
155.750(e):	Overfill Protection for Oil and Hazardous Materials	43
155.750(c):	Benzene Cargo Transfer Procedures Guidelines (Note: Not required but good reference to those requirements in 46CFR Part 197)	45
	I. Cargo Transfer Guidelines	45
	II. Benzene Transfer Procedures	46
	5.3. USCG Safety Data Information - Benzene	48

SECTION 155.750 (a)(1):

CARGO INFORMATION

I. PROPER SHIPPING NAMES AND REGULATORY COMPLIANCE

This barge is certificated for the transport of 46 CFR Subchapter “D” and Specified Dangerous Cargoes under 46 CFR Subchapter “O”.

The **Subchapter “D”** cargoes **NEED NOT BE LISTED ON THE C.O.I.** for loading (unless a vapor recovery load), transport, or unloading operations, but need to be within the approved flammability limits. This barge is approved for all Grade A and lower, thus the only Subchapter “D” products not authorized are the liquefied flammable gases.

Subchapter “O” cargoes **NEED TO BE LISTED ON THE C.O.I.** by the appropriate name for loading, (including vapor recovery), transport and unloading operations.

Attached to this section is a table which lists the USCG names for various cargoes. The only authorized names for the cargoes are those listed in the table. Operations for cargoes by any other name are illegal.

The Subchapter “O” cargoes in the table are indicated by the letter “O” (handwritten) on the line immediately following the cargo name.

The remaining cargoes in the table are either Subchapter “D” or not regulated.

In any case, the cargo name you are presented with must match a name in this table. Mixtures of the Subchapter “D” or non regulated products are authorized as long as each component in the mixture has a name which can be found in the table.

Mixtures containing any Subchapter “O” products are not authorized unless the mixture by itself has a USCG approved name listed in the table.

Sometimes trade names or other names will be presented to you, which do not match the authorized USCG name. Here are the steps you should take:

1. The MSDS is the most accurate source of information available for the given cargo. Try to find a synonym for the product under this section in the MSDS. The Chemical Data Guide might be another good source for synonyms. If you find a match, the product has been identified by the USCG.

SECTION 155.750(a)(1) continued:

2. If a Mixture of products, look at the MSDS and see if the components are listed separately in the table. If this is the case, then mixtures has a USCG authorized name. However, if any of the components of the mixture are Subchapter "O", then the mixture is not authorized unless listed on the COI with its properly assigned USCG name.
3. If you cannot get a match in any case, then contact your supervisor, and recommend that contact be made with the customer to find the appropriate USCG Shipping Name for barges. It is not your fault that this situation exists because the customer is responsible for ensuring that their product has the proper USCG shipping name; but as part of your pre transfer inspection, you are the last line of defense to ensure legality.
4. Remember, in the case of Subchapter "O" products, even if you get a match in names, the cargo must be listed on the COI for approved operations.

Remember for vapor recovery loading operations, both Subchapter "D" and Subchapter "O" cargoes have to be listed in one way or another on the C.O.I. Refer to the section on vapor control operations of these transfer procedures for specifics. Note that the table also listed the three letter "CHRIS" code, which is important for verification on some COI's, since the CHRIS code instead of the complete name might be listed.

II. HAZARD INFORMATION SYSTEMS AND SOURCES

Due to the many cargoes that Kirby barges are certificated for, it makes no sense, as had been done in the past, to use generic information sheets from the voluminous CHRIS manuals, unless the barge was dedicated to a specific product. Further, the CHRIS information is too generic in nature. However, PIC's should ensure that the following information systems are available to ensure compliance with USCG regulations:

For Subchapter "D" cargoes, the MATERIAL SAFETY DATA SHEET (MSDS) needs to be reviewed by you and made readily available to all interested parties involved with the barge operation. This includes USCG personnel when you are boarded and asked to provide such.

For Subchapter "O": cargoes, the regulations require that a CARGO INFORMATION CARD (CIC) be posted by the barge's warning sign and remain there until the product is changed or the barge is cleaned and gas free. If a CIC is not available, at least ensure that an MSDS is posted in its place. The USCG still could possibly issue you a citation for not having a CIC, but they might ease off if at least the information is available. This way the spirit of the regulation is met, if not the letter, so to speak.

SECTION 155.750(a)(1) continued:

As a minimum, and according to the regulations governing the contents of this section of the transfer procedures, the MSDS, CIC, or appropriate cargo information source must contain the following information. The PIC must be familiar with the following particulars and ensure quick access to the information source when needed:

1. Identification of the cargo, including the appropriate regulatory shipping name as designated by the USCG in Tables 46 CFR 151.05 (Subchapter "O"), and 46 CFR 30.25-1 (Subchapter "D") or the other correspondence as provided by the USCG Commandant. Note: instead of referring to these regulatory references, you can check for the correct name in the table of these procedures as discussed in the previous **SUBSECTION "I"**.
2. Physical and chemical properties addressing the appearance and odor. Be aware of the ODOR THRESHOLD LIMIT in particular, and how it compares with the TLV or PEL values. If it is higher than the PEL or TLV, you might be exposed to dangerous levels prior to detecting such through sense of smell.
3. A statement of the hazards involved and instructions for the safe handling of the cargo as applicable, the need for special cargo environmental control such as inert padding and inhibitors or stabilizers.
4. Emergency procedures stating the necessary precautions in the event of spills, leaks, or equipment/machinery breakdowns and/or uncontrolled release of cargo in to the atmosphere or the waterways.
5. Precautions to be observed in the event of personnel exposure to toxic cargoes.
6. Fire fighting procedures to be used in the event of a fire occurring on or adjacent to the barge, and utilization of the limited equipment available for response.

As stated earlier, the Cargo Information Cards for Subchapter "O" cargoes are required by law so use them. Unfortunately, they, like all other CHRIS based information, are too generic in nature. DUE to the various "different" types of cargoes provided by the customers, it is best for the PIC to ensure that the MSDS is reviewed and always readily available. THE MSDS IS THE MOST ACCURATE SOURCE OF INFORMATION AVAILABLE, because they are, or at least should be, specific to the particular product manufactured by the customer. Unfortunately, the MSDS is not a very "user friendly" format for marine PIC's. That is why the PIC must take the time to review the information as noted above, and any additional information of concern. The MSDS must be made available to you under the "Right to Know" laws, so ask for it.

As previously mentioned, the remaining pages of this section of these transfer procedures are dedicated to the table which lists all cargoes by the USCG authorized names.

SECTION 155.750(a)(2):

BARGE TRANSFER SYSTEM

I. PIPING DIAGRAM (S)

Please review the contents of the piping diagrams of this section.

Note for Stripping Systems:

Ensures that the following as a minimum are met prior to activating the stripping system:

- 1. Establish proper system line up.**
- 2. Check for packing leaks at the stripping pump and ensure a snug fit.**
- 3. Check for hydraulic fluid leaks at the stripping pump and ensure a snug fit.**
- 4. Ensure that the pump engine is operating at 1800 RPM.**

PORT

STERN

BOW

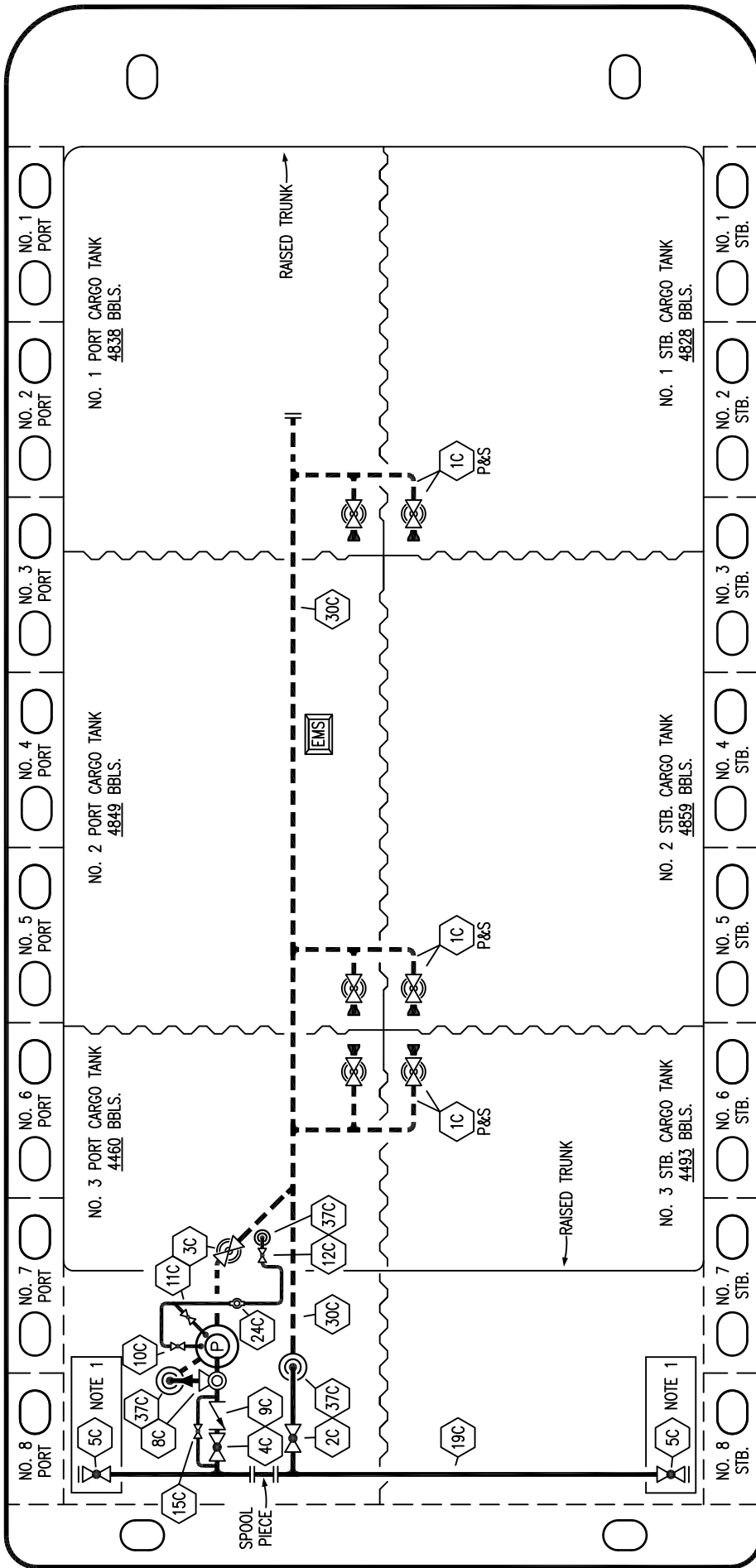

STARBOARD

NO	DESCRIPTION
1C	CARGO TANK VALVE
2C	LOAD VALVE
3C	MASTER SUCTION VALVE
4C	DISCHARGE VALVE
5C	HEADER VALVE
8C	RELIEF VALVE
9C	CHECK VALVE
10C	BURP VALVE
11C	BLEED OFF VALVE
12C	BURP VALVE RETURN TO CARGO TANK
15C	BYPASS VALVE AROUND CHECK
19C	CARGO HEADER
24C	FLOW INDICATOR
30C	CARGO PIPELINE
37C	CARGO DROP
---	ABOVE DECK PIPING
---	BELOW DECK PIPING

NOTE 1: CONTAINMENT P/S



KIRBY INLAND MARINE

CARGO

PIPING FLOW DIAGRAM

REV.	DATE	BY	CHK	APP	ISSUED FOR APPROVAL	REVISION DESCRIPTION
0	04/24/17	WFB	DDA			

SCALE: NONE
PAGE: 1 OF 3

WEST GULF MARINE INC.

REV. **0**

KIRBY 29066

PORT

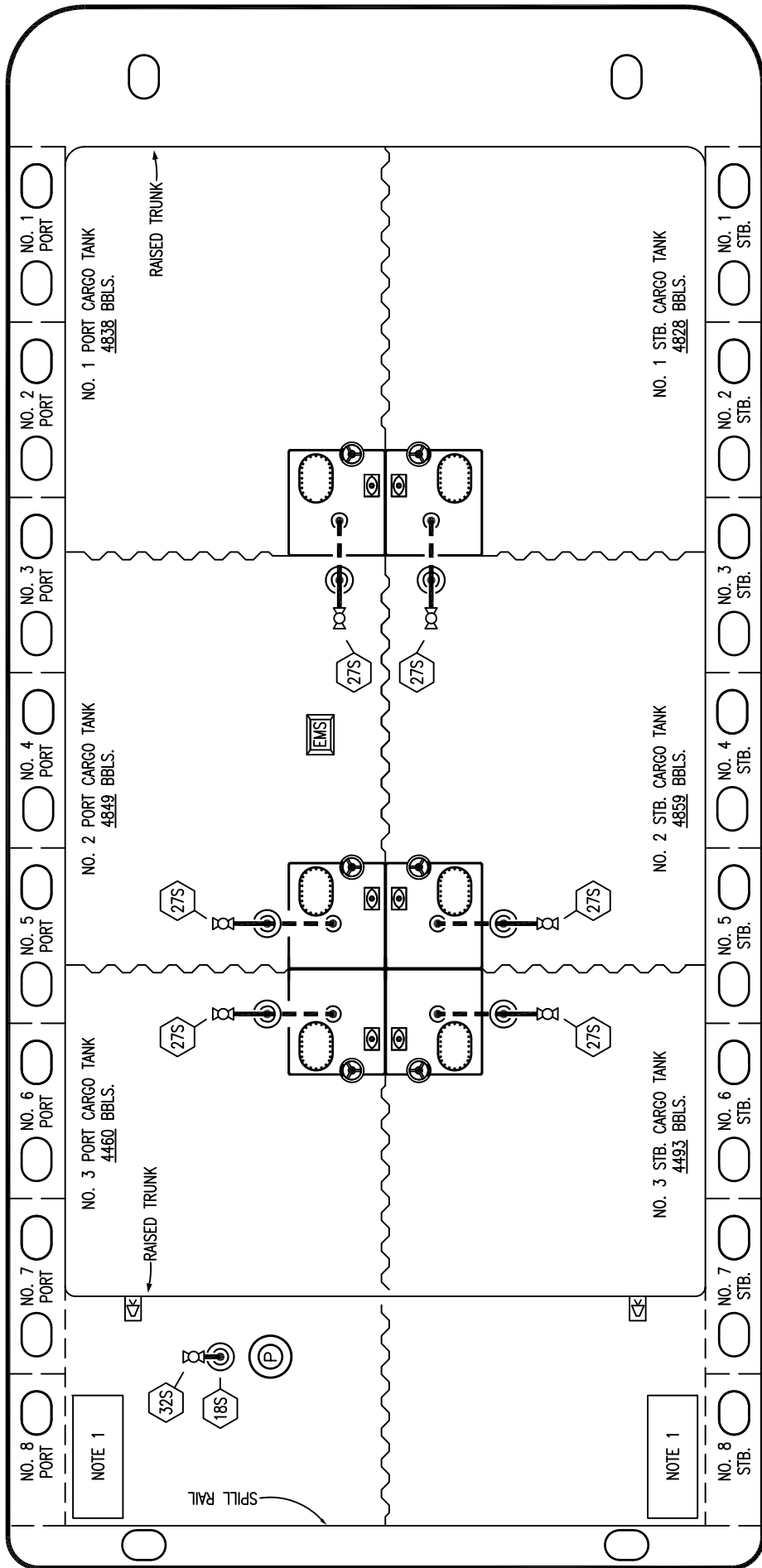

STERN

STARBOARD

DESCRIPTION

- 18S TYP. STRIPPING DROP
- 27S SUMP SUCTION VALVE
- 32S PUMP WELL PRIMER VALVE
- ABOVE DECK PIPING
- - - BELOW DECK PIPING

NOTE 1: CONTAINMENT P/S

WEST GULF MARINE INC.



STRIPPING

PIPING FLOW DIAGRAM

REV.	DATE	BY	CHK	APP	ISSUED FOR APPROVAL	REVISION DESCRIPTION
0	04/24/17	WFB	DDA			

SCALE: NONE	REV. 0
PAGE: 3 OF 3	KIRBY 29066

SECTION 155.750(a)(2) continued:

II. PROCEDURES FOR EMPTYING DISCHARGE CONTAINMENT

The pollution pen or coaming around the machinery area must have scuppers with the plugs inserted. Since the barge has drip pans of the correct capacity, this coaming is an extra support to pollution prevention. It is to be expected that some water might be contained within this area, and it is usually desired to drain this water off. However, if a sheen is visible on this water, then simple draining cannot be done since the intent of the regulations is to avoid the spillage of any oil or hazardous material into the water. Further, an additional storm or variations in barge trim might cause an overflow of the sheen/water mixture. The PIC is advised to monitor the levels within the coaming and take into account the various barge trim (especially during unloading operations) and approaching weather conditions expected during the transfer. The barge might have to be brought to the shipyard for proper disposal of this sheen/water mixture prior to the transfer.

SECTION 155.750(a)(3):

PERSONS ON DUTY DURING TRANSFER OPERATIONS

USCG regulations state that no person may serve as the PIC (PERSON IN CHARGE) of transfer operations on more than one vessel at a time during transfers between vessels or between two or more vessels at a facility unless authorized by the COTP MSO zone serving as the location of the transfer. These waiver authorizations (as LETTERS OF ALTERNATIVE COMPLIANCE) must be in writing and are placed in the front of these transfer procedures as required by the USCG.

If you are involved in such a transfer, read the Letter of Alternative Compliance from the USCG MSO that applies to your location. Bear in mind that USCG waivers of this nature have some operational contingencies you need to comply with, and they might vary between MSO zones. Read the correct one for your zone of transfer.

The PIC shall be aboard the barge at all times when the transfer operations are in progress. Do not be fooled by the statement in the regulations which state that the PIC needs to be in the "immediate vicinity." That statement is based on the assumption similar to ships where an entire watch is conducting the transfer. YOU are the watch. You are to remain on the barge. People have been written up by the USCG for standing on the gangway, so be careful.

Further, trainees are not yet licensed tankerman, or they would not be trainees. Do not be tempted to let the trainee stay on the barge while you, as the PIC, remain on the dock or in the dock shack in the "immediate vicinity." That will not work, either.

SECTION 155.750(a)(4):

DUTIES OF TANKERMAN (PERSON IN CHARGE)

2.4(a) COAST GUARD REGULATIONS FOR TRANSFER

According to the Coast Guard regulations found in 33 CFR Part 156.120, a transfer operation may not commence unless:

- A. The vessel moorings are checked to verify that they are strong enough to hold during all expected conditions of surge and current and allow for change in draft, drift, and tide;
- B. The transfer hoses and loading arms are long enough to allow the vessel to move within the limits of its moorings without placing a strain on a hose, loading arm, or piping system;
- C. Each hose is supported to prevent chaffing, kinking, or other damage to the hose or hose couplings;
- D. The PIC verifies that each appropriate transfer system is aligned to allow the proper flow of cargo;
- E. Each part of the transfer system not in use is securely blanked or shut off;
- F. Each end of any hose and loading arm that is not in use is securely blanked off with a blind flange;
- G. The transfer system is attached to a fixed connection on the vessel and the facility, except when a vessel is receiving fuel, then an automatic back pressure nozzle may be used;
- H. Each overboard discharge (if fitted) or sea suction valve that is connected to the vessel's transfer system or cargo tank system is sealed or locked in the closed position;
- I. Each transfer hose has no unrepaired loose covers, kinks, bulges, soft spots, or any other defect which would permit the discharge of oil or hazardous materials through the hose. The hose must not have gouges, cuts, or slashes that penetrate the first layer of the hose reinforcement;

- J. Each hose or loading arm meets 33 CFR Part 154.500 and 33 CFR Part 154.510;
- K. Each connection meets the following requirements of 33 CFR Part 156.130:
 - 1. Uses suitable material in joints and couplings to ensure a leak-free seal;
 - 2. Uses a bolt in every hole, no case less than four bolts, in each temporary bolted connection that uses a flange that meets ANSI standard flange requirements under 33 CFR Part 154.500(d)(2);
 - 3. Bolts and nuts must be tightened to uniformly distribute the load and ensure a leak-free seal;
- L. Any monitoring devices required by 33 CFR Part 154.525 are installed properly and operating properly;
- M. The discharge containment equipment required by 33 CFR Part 154.545, as applicable, is readily accessible or deployed as applicable;
- N. The discharge containment required by 33 CFR Parts 154.530, 155.310, and 155.320, as applicable, is in place and periodically drained to provide the required capacity;
- O. Each drain scupper or spill rail plug is double checked and closed securely;
- P. All connections in the transfer system are leak free; except for those components in the transfer system, such as the packing glands of a pump, may leak at a rate that does not exceed the capacity of the discharge containment provided during the transfer operation;
- Q. The communications required by 33 CFR Parts 154.560 and 155.785 are operable for the transfer operation;
- R. The emergency means of shutdown required by 33 CFR Parts 154.550 and 155.780, if applicable, is in position and operable;

- S. There is one PIC on both the transferring and receiving vessel or facility unless otherwise authorized ;
- T. Each PIC on duty at the site of the transfer operation, has checked to ensure that a copy of this manual is on the barge; As appropriate, the PIC conducts the operations according to the manual and is immediately available to transfer personnel during the transfer operation;
- U. The PIC of the dock facility or other vessel boat speak the same language (English);
- V. The transfer is conducted in accordance with all local, state, and federal regulations;
- W. A conference must be held between the person-in-charge of the dock facility vessel and PIC. They must understand all of the following details of the transfer operation:
 - 1. The identity of the product to be transferred;
 - 2. The sequence of the transfer operations;
 - 3. The transfer rate;
 - 4. The name or title, and the location of each person involved in the transfer operations and the procedures for relieving watch or changing the shift;
 - 5. Details of the transferring and receiving system;
 - 6. Critical stages of the transfer operations;
 - 7. Federal, state, and local rules that apply to the transfer;
 - 8. Emergency procedures;
 - 9. Discharging containment procedures;
 - 10. Discharge notification procedures (vessel to vessel, or vessel to dock);

11. Watch of shift change arrangements;
 12. Transfer shutdown procedures;
 13. The Declaration of Inspection has been signed, and is in the possession of the PIC;
- X. The PIC of transfer operations on the vessel or facility loading the cargo and the PIC of transfer operations of the receiving vessel or facility agree to begin transfer operations;
 - Y. The transfer operation between tank barges and the dock facility is adequately lighted between sunset and sunrise;
 - Z. Any restrictions on loading and discharging by the USCG Captain of the Port for the particular zone or facility are verified by checking on the Coast Guard authorization letter which is provided in the front of this manual, and,

SECTION 155.750(a)(5):

TENDING VESSEL MOORINGS DURING TRANSFER OPERATIONS

Proper mooring of the barge is essential for both safety and pollution prevention. You may not transfer cargo to or from a barge unless its moorings are strong enough to hold in all expected conditions of surge, current, and weather. The mooring lines must be long enough to allow for changes in draft, trim, surge, and tide during transfer operations.

All conditions at the dock must be considered to determine the adequate size, proper lead and the number of lines necessary. Surge of the barge, both at parallel to and at right angles to the dock, will be influenced by the proximity of traffic in the channel, the dock design, the state of the tide and the barge's draft. Be sure that all lines have the proper lead and are secure.

Be particularly mindful of docks with high and low mooring dolphins, etc. It may be necessary to shift from lower mooring supports to higher or visa versa, as the barge goes down or comes up from the water.

When mooring the barge, as a MINIMUM standard, the PIC should ensure that the number of mooring lines used is in accordance with the governing Standard Operating Procedures for the service of this barge. The lines are used in combination to fulfill the following functions:

- (1) Towing lines
- (2) Backing lines
- (3) Spring lines

SECTION 155.750(a)(6):

PROCEDURES FOR OPERATING THE EMERGENCY SHUTDOWN AND PROVISION OF COMMUNICATIONS

I. EMERGENCY SHUTDOWN OPERATIONS

In case of hose rupture, tank overflow, or other emergency, normal means of stopping the flow of product may require inadequate time to properly arrest it. To ensure a more timely, if not immediate, shutdown, both the vessel and facility are required to have emergency shutdown equipment.

The facility must have an emergency means to enable the person in charge the transfer on board the vessel, at that person's usual operating station, to stop the flow of oil or hazardous material from the facility to the vessel. The means must be – (1) An electrical, pneumatic, or mechanical linkage to the facility; or (2) An electronic voice communications system continuously operated by a person on the facility who can stop the flow of oil or hazardous material immediately.

For unloading situations, in addition to the facility provided system, the barge is required to have a means of shutting down the barge transfer system by shutting off the driver for the cargo pump; in this case a diesel powered engine. This is accomplished with the use of a simple shutdown cable which is connected to close the air intake "flapper" of the engine. This activation point of the shutdown cable needs to be at least 100' away from the engine. This should be tested by grabbing the handle of the cable at the marked shutdown station and pulling upwards. Then inspect the intake area of the engine to ensure proper closure of the flapper valve.

Be suspicious of barges which have the cable strung through a lot of corners and edges back in the machinery flat area. Do not check the operation at closer locations than the remote station.

Due to engine wear from the past, it is not recommended to start up the engine and check for proper shutdown operation by seeing if the engine dies. However, if you are suspicious of complete flapper valve operation, then test the shutdown with the engine idling at very low rpm's.

SECTION 155.750(a)(6) continued:

II. COMMUNICATIONS

In vessel to vessel transfers, and vessel to facility transfers, there must be a means of continuous two-way voice communications between the Persons in Charge of each entity.

The means of communication must be usable and effective in all phases of the transfer operation and in all conditions of weather.

If portable radio devices are used to comply with this requirement, they must be intrinsically safe as defined in 46 CFR 110.15-100(f), and meet Class 1 Division 1 Group D requirements as defined in 46 CFR 111.80.

Be Careful during unloading operations when you are within the vicinity of the operating pump engines. More frequent radio or other voice communication checks may be necessary to ensure timely notification.

SECTION 155.750(a)(7):

PROCEDURES FOR TOPPING OFF TANKS

Prior agreement in the reduced transfer rates to be used during topping off and trimming the barge should be discussed during the pre transfer conference. The PIC must give the facility PIC proper notice before topping off the final tank so that the flow rate can be reduced in preparation for the final shutdown. Further, reduced loading rates should be agreed upon when the initial topping off of the first set off tanks begins, if desired. Reduced rates or shutdown procedures should be discussed and utilized whenever something does not look right or if problems should arise during the topping off stage.

Generally, in a simultaneous (non split) load the barge SHOULD BE TOPPED OFF FROM BOW TO STERN making certain that it is kept as level as possible to prevent system load; or from entering the common vent system or leaking through butterworths. ALTHOUGH BOW TO STERN TOPPING OFF IS STRONGLY ENCOURAGED YOU CAN DEVIATE FROM THIS SEQUENCE IF THE BARGE APPEARS TO TRIM IN A MANNER SUPPORTING SUCH. This could happen due to different barge designs and cargo specific gravities.

Top off only one tank at a time. It is best to either close or restrict flow by pinching down on the valves to those tanks adjacent to the one being topped off. For example, assuming a bow to stern sequence, while topping of the #1's, the #2's might be pinches down, with the #3's either pinched down more than the #2's, or perhaps closed.

As the product level approaches the required level in the tank, pinch down on the tank valve, and open more of the valves in the adjacent tank or tanks. This helps in reducing hammer pressure on the piping. For example, as the required level is approached in the #1's, pinch down on the #1's and open more of the #2's.

Once the product reaches the desired level in the tank, close the valve tightly, then re-open it to slightly wash away scale in the valve gate. Close it again tightly.

Use the same sequence of pinching down, opening, and closing, the valves to the tanks of concern and those adjacent tanks as you top off in the proper direction. IT IS BEST TO BEGIN TOPPING OFF WHEN THERE IS ABOUT TWO TO THREE FEET OF CARGO TANK SPACE IN EACH REMAINING SET OF TANKS. This outage might be higher if the barge for one reason or another is not trimming too evenly up to this point.

While topping off the last tank, ensure that enough room is left for the hose draining or line blowback.

SECTION 155.750(a)(7) continued:

Once the facility PIC is informed of the shutdown, ensure that the facility shore side valves are closed first before the barge header valves. This prevents over-pressurization of the transfer hose or loading arm.

The following additional points are important to remember:

- A. Closing off one tank valve increases the rate of flow to the other tanks of the system
- B. The rate of flow into any tank which is nearly full can quickly be reduced by opening the valve to another tank.
- C. The greater the pressure against a valve (such as head pressure), the longer it will take to open it.
- D. The liquid level in topped off tanks should be checked frequently to ensure that the liquid level is not rising. This may occur if the barge stripping system is not properly secured or if the cargo valves are leaking.

NOTE: On 10,000 bbl barges, no more than 18 inches of trim allowed.

SECTION 155.750(a)(8):

PROCEDURES FOR ENSURING ALL VALVES ARE CLOSED

Upon completion of barge transfer operations and the clearing of the dock cargo hose or pipeline, the PIC should perform the following procedures on the barge:

1. Close the cargo tank valves, the loading valve (to the load drop), or pump suction and discharge valve, and the header valves.
2. Ensure all valves of the cargo system are closed on the barge.

EXCEPTIONS TO THE PROCEDURE

1. Freezing cargos procedure needs to follow (KIM 07.362)
 2. Asphalt / VTB procedure needs to follow (CPRM G7.302)
 3. Valve has been locked open with Lock out / Tag out
3. Close the vent stack if the product of load or discharge (since there are still vapors present in the tanks) is a Grade A, B or C flammable liquid, or if it is Subchapter "O" cargo which requires "PV" venting in lieu of "OPEN" venting. If you are not sure of the venting requirement for a particular Subchapter "O" cargo, then check the table 46 CFR 151.05 or bring this matter to the attention of your supervisor. If you are unsure of the flammability grade of a Subchapter "D" cargo, then check the MSDS. Also, the terminal might require the vent stack to be closed after the transfer even if not required by USCG regulations, so be aware of this.

SECTION 155.750(a)(9):

PROCEDURES FOR REPORTING DISCHARGES OF OIL AND HAZARDOUS MATERIALS

In the event a discharge of oil or hazardous material occurs on deck or in the water, the PIC must shut down the transfer operation and notify the wheelhouse person on watch of the accidental discharge. Wheelhouse personnel will contact the appropriate dispatch office who will notify the appropriate USCG office(s).

The PIC will also take immediate action to protect personnel from exposure to hazardous chemical vapors by moving upwind and if necessary, donning personal protective equipment.

If the spill is contained on deck the dispatch officer will probably not notify the USCG. If the Spill is in the water then the USCG will be notified. You, as the scene PIC must be prepared to provide at least the following information to those who will be notifying the appropriate government agency:

1. Barge name
2. Time of the incident
3. Geographic location of the barge
4. Wind and tide conditions
5. Condition of the barge, particularly the equipment that might be associated with the discharge.
6. An estimate of the quantity of product discharge into the water; or the amount contained on deck.

SECTION 155.750(a)(10):

PROCEDURES FOR CLOSING AND OPENING THE VESSEL OPENINGS

Upon the completion of transfer and preparatory to getting underway, the PIC shall ensure that all closure mechanisms on the following openings are properly closed:

1. Expansion trunk hatches
2. Ullage openings
3. Sounding ports
4. Tank cleaning butterworth openings
5. Any other tank openings that maintain the seaworthy condition of the barge and prevent the inadvertent release of oil or hazardous material in the event of an accident. This includes, therefore, the rake void, and wing/innerbottom voids.

No person is allowed to open any of the closures mentioned above while underway or fleeted unless authorized to do so by the person in charge.

SECTION 155.750(a)(11):

CARGO HOSES CARRIED ON BARGES

History has taught us that cargo hoses can be a weak link in the transfer system, so the USCG regulates them rather stringently. All we are required to address are hoses attached or assigned to the barge, but the PIC should bear in mind that an incident resulting from improper use of a facility hose used for facility/barge hook up might also result in the USCG citing the barge PIC under 33 CFR 156 for DOI items. It is best that the PIC take note of the following and apply the principles to ALL hoses used in the transfer.

Hose MAWP as marked should at least be 150 psig.

The hose should be marked with the words "OIL SERVICE", or if in hazardous material "non oil" service, by chemical name. If the marking references "HAZMAT SERVICE See.....", which is another sheet of paper or document on the barge, and if that document is not available, check with your supervisor.

The MAWP is required to be marked on the hose as well.

Hoses are pressure tested annually. If the test date is not marked on the hose, check the supporting paperwork to ensure a valid and current test date. Ensure that the hose serial# marked on the hose matched the serial # referenced in the supporting paperwork.

Hoses involved in the transfer should not have loose covers, kinks, bulges, soft spots, gouges, cuts, slashes that penetrate the reinforcement. The hose should have no external deterioration and, to the extent internal inspection is possible with both ends open, no internal deterioration.

Ensure that hoses are supported so that they are not pinched between the barge and the facility. Ensure they are long enough to allow the vessel to move within the limits of its moorings to avoid placing strain on the hose of manifold systems.

Inspect the hose frequently during the transfer. Remember, it is the weak link.

Do not let the hose fall to the deck during handling, connecting or disconnecting.

Any hose that is not clean and gas free must be blanked off.

SECTION 155.750(d)(1):
VAPOR SYSTEM PIPING & ARRANGEMENT DIAGRAM

ATTACHED IS THE VAPOR PIPING DIAGRAM FOR THIS BARGE

BOW

PORT

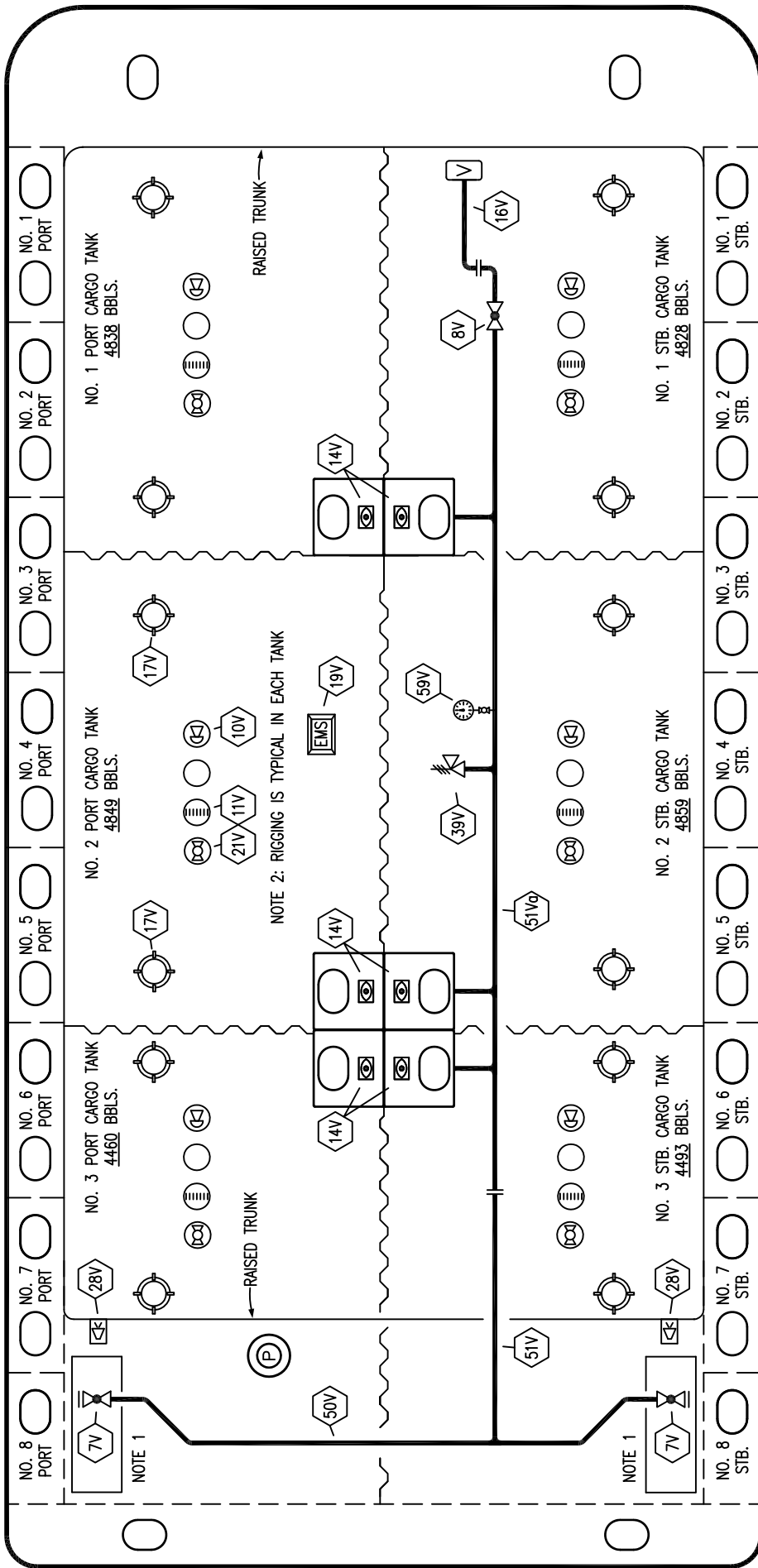

STERN

STARBOARD

NO	DESCRIPTION
7V	8" HEADER VALVE
8V	8" VENT STACK VALVE
10V	8" HIGH LEVEL/OVERFILL ALARM
11V	8" 1-METER STICK GAUGE
14V	8" SIGHT GLASS W/GAUGE TREE
16V	8" VAPOR VENT STACK
17V	20" BUTTERWORTH
19V	EMERGENCY ENGINE SHUT DOWN
21V	2" HERMETIC GAUGE
28V	DOCK CONNECTION ALARM
39V	PRESS/VAC RELIEF VALVE
50V	8" VAPOR HEADER
51V	8" VAPOR PIPELINE
51Vg	10" VAPOR PIPELINE
59V	PRESS/VAC GAUGE
—	ABOVE DECK PIPING

NOTE 1: CONTAINMENT P/S
NOTE 2: RIGGING IS TYPICAL IN EACH TANK

WEST GULF MARINE INC.



KIRBY INLAND MARINE

VAPOR

PIPING FLOW DIAGRAM

REV.	DATE	BY	CHK	APP	ISSUED FOR APPROVAL	SCALE:	PAGE:	REV.
0	04/24/17	WFB	DDA			NONE	2 OF 3	0

SECTION 155.750(d)(2):

LOCATION OF SPILL VALVES OR RUPTURE DISKS

SPILL VALVES or RUPTURE DISCS ARE LOCATED AS PER THE VAPOR PIPING DIAGRAM OF SECTION 155.750(d)(1). ONE DEVICE PER CARGO TANK IS USED. IF THEY ARE NOT ON THIS DIAGRAM, THEN THERE SHOULD NOT BE ANY ON THE BARGE.

SECTION 155.750(d)(3):

DETERMINATION OF MAXIMUM ALLOWABLE TRANSFER RATE

There is no documentation of a maximum allowable loading rate in the USCG files for this barge. Therefore, without additional checks, the maximum allowable rate is the one which ensures that the pressure in the most remote area of the barge from the header never exceeds 80% of the PV pressure setting.

The following worksheets are provided to assist in checking the PRESSURE DROP criteria, which is the most critical factor in determining whether or not a given loading rate will ensure that no part of the barge is exposed to more than 80% of the PV pressure setting.

Section I covers a situation where the desired loading rate is checked and the dock does not require any specific pressure drop across the barge. It is for a pressure vapor control system. Please note that you might have some back pressure once vapor lines are hooked up and equalized, so it is best that this takes place before the desired loading rate is checked.

Section II covers a situation where the dock specifies a certain pressure drop across the barge, and the loading rate is determined from this criteria. This applies for both pressure and vacuum systems.

Section III covers a situation where the dock does not specify a limiting pressure drop across the barge, and the load is under vacuum system. It is the easiest to monitor.

The procedures contain blank worksheets that you can use as a guide on SEPARATE PAPER. Please do not mark them up.

Following the blank worksheets is a SAMPLE CALCULATION on the same worksheets, this time with the date hand written. It is based on the following examples:

Case I: BENZENE is loaded with a desired loading rate of 3500 bbls/hr. You'll need to see if this loading rate is OK and then check to see what the "danger" point pressure readings will be on your manometer or pressure gauges, which you will monitor during the transfer.

Case II: BENZENE is to be loaded and the terminal does not want the pressure drop across the barge to be greater than .1 psi. You will first determine the loading rate which cannot be exceeded.

Some terminals may even have their own worksheets, so all you need to do in this case is provide them with the pressure drop. REMEMBER, THE PRESSURE DROP TABLES CAN BE FOUND IN SECTION 155.750(d)(5) of these procedures.

SECTION 155.750(d)(3) continued:

Note that for desired loading rates which are less than the smallest loading rate shown on the appropriate Table, then use the pressure drop for the lowest rate listed.

For example, let's say the lowest rate on a given Table is 2500 bbls/hr, but you desire to load at 1500 bbls/hr. Use the pressure drop figure for the 2500 bbls/hr loading rate. This is a safe approximation.

SECTION 155.750(d)(3) continued:

VAPOR CONTROL SYSTEM:

DETERMINATION OF LOADING RATE

I. LOADING UNDER A PRESSURE SYSTEM WHERE TERMINAL DOES NOT SPECIFY LIMITING PRESSURE DROP.

A. Establish pressure not to be exceeded: (This will always be the same for this barge regardless of the product. It is 80% of the pressure setting: _____

B. Record desired loading rate: _____ BBL/S

C. Record cargo vapor density: _____

D. Decide which pressure drop Table to use: _____

SEE SECTION 155.750(d)(5) for TABLES

If vapor density is up to 2.0, use Table I

If vapor density is above 2.0, up to 3.0, use Table II

If vapor density is about 3.0, up to 4.0, use Table III

If vapor density is about 4.0, up to 5.0, use Table IV

E. For the loading rate chosen in "B", select the pressure drop from the Table chosen in "D": _____

F. Record the pressure on the barge after hook up and equalization from opening the vapor line: _____

G. Add "E" and "F": _____

H. If "G" is less than "A", the loading rate is OK. If not, repeat steps "A" through "H" again, this time at a lower loading rate.

I. Determine the maximum reading on your manometer or pressure gauge during the transfer:

1. Record the value of "A": _____

2. Record the value of "E": _____

3. Subtract "E" from "A"; or "A" minus "E": _____

4. The pressure reading on your gauge or manometer cannot exceed this pressure as indicated above in #3.

SECTION 155.750(d)(3) continued:

VAPOR CONTROL SYSTEM:

DETERMINATION OF LOADING RATE

II. LOADING UNDER A PRESSURE OR VACUUM SYSTEM WHERE THE TERMINAL SPECIFIES THE ALLOWABLE PRESSURE DROP ACROSS THE BARGE.

This occurs when the terminal wants a loading rate which ensures that your barge does not exceed pressure drop across the barge. If this is the case, then proceed as follows:

J. Record desired pressure drop not to be exceeded: _____

K. Record cargo vapor density: _____

L. Find the correct Table using the process outlined in step "C" of this worksheet:

M. From the correct Table in "L" above, select the flow rate which is closest to a corresponding pressure drop required in "J" without exceeding your chosen loading rate must be less than this value: _____

N. The dock should keep you informed of which pressure reading to monitor in order to maintain their pressure their pressure drop requirements. In absence of that, you are still required by the USCG to establish your safe pressure setting. Therefore, go back to Section I, step "A" through "I" and establish your safe pressure reading for the chosen loading rate.

III. LOADING UNDER A VACUUM SYSTEM WHERE THE TERMINAL DOES NOT ESTABLISH REQUIRED PRESSURE DROP ACROSS THE BARGE

O. Maximum vacuum is at the header for this system. If the manometer reads 11 inches of H₂O or .4 psig VACUUM, advise the dock.

SECTION 155.750(d)(4):

INITIAL TRANSFER RATE FOR EACH CARGO TANK

Precautions against static electricity accumulation and/or generation may be necessary when the cargo being handled is an accumulator or generator of static electricity. Bonding and grounding is not enough. Therefore, certain precautions are to be taken during the initial movement of product into the tanks during the loading operation. It is wise to adhere to this principle for all products which are not good conductors, like most light hydrocarbons, and those particularly known for static accumulation properties such as the following:

Natural Gasolines

Kerosenes

White Spirits

Motor and Aviation Gasolines

Jet Fuels

Naphthas

Heating Oils

Heavy Gas Oils

Clean Diesel Oils

Lubricating Oils

The PIC of the barge should determine whether an anti-static additive has been used by checking the MSDS or other means of verification from the terminal. If not, as a minimum, the following guidelines for initial loading rates should be used. These figures are equivalent to a flow rate of 3 linear feet per second which is a recommended standard for a safe flow rate. Obviously, since you do not load barges in rates of ft/sec, the bbls/hr conversion will vary depending on the pipe diameter size:

Pipeline Diameter	Approximate flow rate (bbls/hr)
3"	105
4"	180
6"	420
8"	730
10"	1,150
12"	1,650

The above rates are recommended PER CARGO TANK DROP, so if you have 6 tanks with 8" drops, your initial rate could be (730 x 6) or 4380 bbls/hr, assuming that you have equal flow into all tanks.

SECTION 155.750(d)(4) continued:

As you can see, the flow rates are still pretty high. Normally, a terminal, if at all possible will gravitate as much product as possible before activating their pumps. The goal is to load at a slow rate in order to minimize the turbulence and (therefore static electricity accumulation) at the bellmouth. This slow rate should be continued until all splashing and turbulence has ceased. Some terminals might want you to load at this slow rate until the longitudinal run of pipeline in the tanks are submerged. Once the desired level is reached, the rate can be brought up to the transfer rate decided upon at the pre transfer conference.

During and for 30 minutes after the completion of loading, ullaging, or sampling equipment must not be introduced into the cargo tanks. Ropes or lines used to lower any equipment into a cargo tank must be made of natural fibers. Synthetic polymers ropes or lines should never be used.

Operations conducted through FIXED sounding tubes are permissible at any time.

If a cargo tank is maintained in an inert condition, then anti static precautions are not necessary.

**SECTION 155.750(d)(5):
PRESSURE DROP TABLES**

THE ATTACHED TABLES I, II, III, & IV ARE PROVIDED IN PRESSURE DROP DETERMINATION. IN ORDER TO USE THEM ONE MUST OBTAIN THE VAPOR DENSITY OF THE CARGO WHICH CAN READILY BE OBTAINED FROM THE MSDS, CIC, OR OTHER INFORMATION SOURCES.

THE CORRECT VAPOR DENSITY DETERMINES WHICH TABLE TO USE. FOR A GIVEN DESIRED LOADING RATE, THE PRESSURE DROP IS GIVEN IN BOTH INCHES OF WATER FOR THOSE SYSTEMS USING MANOMETERS, AND IN PSI FOR THOSE SYSTEMS USING GAUGES AS PRESSURE INDICATING DEVICES.

KIRBY INLAND MARINE, INC. VAPOR RECOVERY SYSTEMS

FOR: All Approved Chemicals

TABLE OF WORST CASE PRESSURE DROPS AS A FUNCTION OF LOADING RATE AND VAPOR DENSITY OF THE CARGO

TABLE I. For Cargoes With Vapor Densities Ranging Up To And Including 2.0

<u>Loading Rate</u>	<u>Pressure Drop</u>	<u>Pressure Drop</u>
3500 bbls/hr	.08 psi	2.2 inches H ₂ O
4000 bbls/hr	.1 psi	2.8 inches H ₂ O
4500 bbls/hr	.126 psi	3.5 inches H ₂ O
5000 bbls/hr	.153 psi	4.2 inches H ₂ O
5500 bbls/hr	.186 psi	5.2 inches H ₂ O
6000 bbls/hr	.214 psi	6.0 inches H ₂ O
7000 bbls/hr	.282 psi	7.8 inches H ₂ O
8000 bbls/hr	.366 psi	10.1 inches H ₂ O

TABLE II. For Cargoes With Vapor Densities Ranging From Above 2.0 Up To And Including 3.0.

<u>Loading Rate</u>	<u>Pressure Drop</u>	<u>Pressure Drop</u>
3500 bbls/hr	.1 psi	2.8 inches H ₂ O
4000 bbls/hr	.13 psi	3.6 inches H ₂ O
4500 bbls/hr	.16 psi	4.5 inches H ₂ O
5000 bbls/hr	.19 psi	5.4 inches H ₂ O
5500 bbls/hr	.23 psi	6.5 inches H ₂ O
6000 bbls/hr	.27 psi	7.6 inches H ₂ O
7000 bbls/hr	.37 psi	10.2 inches H ₂ O
8000 bbls/hr	.47 psi	13.0 inches H ₂ O

KIRBY INLAND MARINE, INC. VAPOR RECOVERY SYSTEMS

FOR: All Approved Chemicals

TABLE OF WORST CASE PRESSURE DROPS AS A FUNCTION OF LOADING RATE AND VAPOR DENSITY OF THE CARGO

TABLE III. For Cargoes With Vapor Densities Ranging From Above 3.0 Up to And Including 4.0.

<u>Loading Rate</u>	<u>Pressure Drop</u>	<u>Pressure Drop</u>
3500 bbls/hr	.123 psi	3.4 inches H ₂ O
4000 bbls/hr	.156 psi	4.3 inches H ₂ O
4500 bbls/hr	.19 psi	5.4 inches H ₂ O
5000 bbls/hr	.24 psi	6.6 inches H ₂ O
5500 bbls/hr	.28 psi	7.9 inches H ₂ O
6000 bbls/hr	.34 psi	9.3 inches H ₂ O
7000 bbls/hr	.45 psi	12.5 inches H ₂ O
8000 bbls/hr	.58 psi	16.0 inches H ₂ O

TABLE IV. For Cargoes With Vapor Densities Ranging From Above 4.0 Up to And Including 5.0.

<u>Loading Rate</u>	<u>Pressure Drop</u>	<u>Pressure Drop</u>
3500 bbls/hr	.14 psi	3.9 inches H ₂ O
4000 bbls/hr	.183 psi	5.1 inches H ₂ O
4500 bbls/hr	.23 psi	6.4 inches H ₂ O
5000 bbls/hr	.28 psi	7.7 inches H ₂ O
5500 bbls/hr	.34 psi	9.3 inches H ₂ O
6000 bbls/hr	.39 psi	10.9 inches H ₂ O
7000 bbls/hr	.53 psi	14.7 inches H ₂ O
8000 bbls/hr	.68 psi	18.9 inches H ₂ O

SECTION 155.750(d)(6):

PV VALVE, SPILL VALVE, AND RUPTURE DISK SETTINGS

NOTE THE SETTING OF THE PV VALVES BY THE ACTUAL SETTING LISTED ON THE VALVE

NOTE THAT THE GOVERNING PRESSURE DURING VAPOR CONTROL OPERATIONS IS 80% OF THE PV SETTING OR:

.8 PSIG for PV set at 1.0 psig

1.2 PSIG for PV set at 1.5 psig

2.4 PSIG for PV set at 3.0 psig

4.8 PSIG for PV set at 6.0 psig

SPILL VALVES ARE SET SLIGHTLY HIGHER THAN THE PV SETTING.

SECTION 155.750(d)(7):

VAPOR CONTROL SYSTEM OPERATION & PROCEDURES

I. PRE-TRANSFER EQUIPMENT INSPECTION REQUIREMENTS

- A. The COI must indicate that the barge is certified for a vapor controlled transfer.
- B. Check the gauge trees, magnetic gauges sticks, high level alarm, and the pressure gauge for proper operation.
 - 1. Loosen packing nut;
 - 2. Lift each cargo tank alarm test rod to its highest position and lower it down again to clear any rod stuck in the alarm or shutdown position;
 - 3. Tighten packing nut.
- C. Check the operation of the pressure/vacuum (PV) valves, when applicable.
- D. Examine the cargo tank sight glasses. Check for cracked glass, leaks or deteriorated wipers.
- E. Check the conditions of all hatches and dogs insuring they are tool tight.
 - 1. Know the cargo hazards, not every cargo hatch should be opened.
 - 2. Report deficiencies to the vessel Captain or wheelhouse person on watch before proceeding with the barge.
- F. Prepare barge for transfer before arrival at the terminal. In addition to the Standard Operating Procedure for Cargo Loading or Discharging other preparations must be made. These items include but are not limited to the following:
 - 1. If necessary, clean compartment sight glasses inside and out.
 - a. Know the cargo hazards, not every cargo hatch should be opened.

SECTION 155.750(d)(7) continued:

2. Put on appropriate respirator and Chemical Protective Clothing (CPC) during this procedure depending on the cargo to be transferred;
 3. Close and dog down all cargo hatches tool tight;
 4. Check vapor pressure gauge.
- G. During the pre-transfer conference additional items for vapor controlled transfer must be discussed. These items include but are not limited to the following:
1. Establish the initial and maximum cargo vapor recovery rate;
 2. Establish the maximum and minimum pressure at the facility and barge vapor connection;
 - a. Use a maximum of eighty percent (80%) of the working limits of the pressure/vacuum valves settings;
 3. Establish when the shore tie power cable for the high level alarm will be connected;
 4. Ensure that the shore-side facility oxygen and hydrocarbon analyzer has been checked in the last 24 hours;
- H. Cargo tank preparation includes but is not limited to the following;
1. If the cargo tanks have been rendered inert:
 - a. Use an oxygen analyzer to check the oxygen content of the cargo tanks;
 - b. Oxygen level must be less than eight percent (8%) by volume;
 2. If the cargo tanks have not been rendered inert:
 - a. The cargo tanks may not be opened during vapor controlled transfer operations unless the following conditions are met:

SECTION 155.750(d)(7) continued:

- 1) Cargo is not being transferred;
- 2) Cargo tanks are at atmosphere pressure;
- 3) Cargo is not required to be loaded closed hatch; and
- 4) A period of at least thirty (30) minutes has elapsed since the cargo transfer stopped.

The PIC should ensure the items on the DOI Vapor Recovery Addendum have been attended to prior to initiating a vapor controlled transfer operation.

II. VAPOR LINE CONNECTION

A. When the PIC is in the process of connecting the vapor hose, that activity includes but is not limited to the following:

1. Ensure that the electrical insulating flange is in place between the barge vapor header and the dock vapor header.
2. Align the vapor collection hose or arm to the vapor header on the barge.
 - a. A one half (1/2) by one inch (1) steel stud must be used on the barge header valve flange;
 - b. Use a new gasket;
 - c. Use a bolt in every hole;
 - d. Secure all bolts evenly, tool tight;
 - e. Double check alignment to the vapor header on the barge;
 - f. Use the pressure gauge to determine how much pressure or vacuum is present within the barge;

B. Connecting the shore tie power cable to the barge includes but is not limited to the following:

SECTION 155.750(d)(7) continued:

1. Connect the high level alarm and automatic shutdown system to the dock receptacle using the five (5) pin shielded shore tie power cable;
2. Use the portable barge high level alarm power supply if the shore tie power cable from the dock is unavailable;

III. TRANSFER PROCEDURES

The following procedures should be followed by the PIC once he commences the cargo transfer operation which includes but is not limited to the following:

- A. When the situation permits, the vessel captain or wheelhouse person on watch is in assistance during the initial start up process;
- B. Begin only when the tankerman in charge and the dock person in charge agree to start;
- C. Open the barge vapor header valve;
- D. Have the dockman open the dock vapor header valve;
- E. Determine the pressure or vacuum level within the barge by reading the manometer;
- F. Equalize the pressure or vacuum between the barge and the dock;
- G. Start the initial cargo flow rate slowly until the cargo loading turbulence subsides in all the cargo tanks;

IV. CLOSED GAUGING SYSTEM

Tank barges are not equipped with a closed gauging system, instead tank barges have a hermetic gauging port to facilitate closed gauging. As such, this provision of 33 CFR Part 155.750 does not apply.

V. HIGH LEVEL ALARM SYSTEMS/AUTOMATIC SHUTDOWN

Testing the auto alarm system includes but is not limited to the following:

- A. Loosen packing nut;

SECTION 155.750(d)(7) continued:

- B. Pull the liquid level alarm rod part way up until the dock alarm sounds;
- C. Pull the liquid level alarm rod further up until the automatic shutdown alarm sounds;
- D. Lower the rod back down to clear and set the alarm switch;
- E. Tighten packing nut;
- F. When using the portable barge power supply note that it activates the high level alarm but does not activate any automatic dock shut down;
- G. Repeat this test on each cargo tank.

If the alarm test on any cargo tank fails to activate the appropriate warnings, the PIC should not proceed with the cargo transfer. The PIC must notify the vessel Captain or wheelhouse person on watch who will contact the HMI dispatcher.

VI. POST TRANSFER/VAPOR LINE DISCONNECTION PROCEDURES

The PIC must perform the following activities once the vapor controlled transfer is completed:

- A. Close the barge vapor header valve;
- B. Have the dock person close the dock vapor header valve;
- C. Disconnect the vapor hose from the barge vapor line. This includes but is not limited to the following:
 - 1. Wear appropriate personal protective equipment;
 - 2. Replace blind flanges insuring new gasket is in place;
 - 3. Use a bolt in every flange hole;
 - 4. Secure all bolts evenly, tool tight;
- D. Disconnect the shore tie power cable from the barge and return it to the dock.

SECTION 155.750(e):

OVERFILL PROTECTION FOR OIL AND HAZARDOUS CHEMICALS

Cargo tanks are fitted with a 1 meter stick gauge that will assist in loading, discharging, and rate determination. For USCG purposes, it is to assist in preventing spills during critical topping off stages; not to be the sole reliable source, of course, but nevertheless, a valuable assisting resource. An overfill alarm system might also be provided, but is not required to comply with 155.750(e), unless a vapor system is installed and there are no spill valves nor rupture disks.

Primary methods of gauging are through either sounding tubes (if provided) and/or the sight glass where open ullages are not used. Gauge trees are provided in various lengths depending on the barge to provide valuable assistance. Monitoring of the 1 meter stick gauge needs to be done in conjunction with actual indication as obtained at these primary areas. Note the following:

1. Locate the overfill protection device(s) by referring to the vapor piping diagram in section 155.750(a)(2) (If barge does not have a vapor control system) or Section 155.750(d)(1) (if barge does have a vapor control system) of these procedures.

WITH REGARD TO THE STICK GAUGE

2. Unscrew the stainless steel cover.
3. Slowly lift the dipstick until you can feel it magnetically interlock with the float.
4. Vertically adjust for specific gravity (if applicable).
5. Constantly check the dipstick level as you are topping off bearing in mind that the second high level alarm should not be tripped (is applicable) and in no case, a load limit of 98.5% be exceeded.
6. As the cargo tank is topped off and the cargo tank valves are closed, continue to monitor the indicator stick which will help indicated whether or not the tank valve is properly closed or leaking.
7. After the transfer, slowly lower the dipstick into its housing. Do not free fall the stick back into its housing.
8. As a general precaution, care should be exercised when gauges are riding high and strong winds are present.

SECTION 155.750(e) continued:

WITH REGARD TO THE ALARM SYSTEM (If applicable)

9. Loosen packing nut.
10. Pull the liquid level alarm rod part up until the dock alarm sounds.
11. Pull the liquid level alarm rod further up until the automatic shutdown alarm sounds.
12. Lower the rod back down to clear and set the alarm switch.
13. Tighten packing nut.
14. When using the portable barge power supply (If applicable) note that it activates the high level alarm but not any dock shut down.
15. Repeat this for each alarm on each cargo tank.

SECTION 155.750(c):

BENZENE CARGO TRANSFER PROCEDURES GUIDELINES

Although the coast guard regulations for this manual do not require that Kirby specifically address the transfer of benzene, Kirby has chosen to include the following information regarding a transfer of product containing benzene.

I. Cargo Transfer Guidelines

These cargo transfer guidelines apply to vessels that are carrying liquid cargoes containing 0.5% Benzene by volume. The term “action level” means an airborne concentration of Benzene of 0.5 parts of Benzene per one million (1,000,000) parts of air, calculated as an eight (8) hour time weighted average (TWA). The short term exposure limit (STEL) means an airborne concentration five (5) parts Benzene per one million (1,000,000) parts of air as averaged over any fifteen (15) minute period. Exposures at the STEL must not be repeated more than four (4) times per day, and there must be at least sixty (60) minutes between successive exposures at the STEL.

No person may be subject to personal exposure in excess of permissible exposure limits unless respiratory protection is used. The Person-In-Charge (PIC) shall ensure that the performance standard of Benzene regulations are compiled with on that person’s vessel. Before a non-employee (i.e., cargo inspector, surveyor, dockperson, etc.) engages in a Benzene operation on the barge, that person must be able to certify that he or she has had within the pervious twelve (12) months at least one (1) medical examination, that the physician who performed the medical examination did not recommend that the person be excluded from areas on the barge where personal exposure may exceed the action level, (2) that respirators and personal protective equipment that will be used by the person while on the vessel meets the requirements of this section, and (3) that respirators that will be used by the person have been fitted and tested in accordance with these rules.

Whenever the airborne concentration of Benzene within an area exceeds or reasonably can be expected to exceed the permissible exposure limits, the person in charge shell restrict access to regulated areas to authorized persons wearing an appropriate respirator and personal protective clothing and equipment. The boundaries of regulated areas must be indicated by barriers, other devices, or by painted areas on the vessel.

A sign bearing the following legend in letters at least three inches (3") high (except the words "DANGER – BENZENE" which must be printed in letters at least fifty percent (50%) larger than the other words) must be posted at each access to the regulated areas, "DANGER – BENZENE, Cancer Causing Agent, Authorized Personnel Only, Respirator Required."

II. Benzene Transfer Procedures

These cargo transfer procedures apply when transferring liquid cargoes containing 0.5% Benzene by volume in the liquid. Content of the Benzene by volume in the particular cargo should be provided by the facility or dock personnel when the pre-cargo transfer discussion is in progress. A Material Safety Data Sheet for the particular cargo should contain this information. To protect yourself from airborne or liquid concentrations of Benzene, all barges shall be loaded using a vapor recovery system where the cargo hatches are closed and sealed tool-tight to prevent the escape of Benzene vapors and liquid. The following requirements shall apply:

- A. All cargo hatches must be closed and dogged tool-tight;
- B. Sight glasses, closed gauging devices, liquid level indicators, gauging trees if installed, must be used;
- C. During closed loading transfers, the Benzene vapors will be returned through the approved Shore Vapor Control System for their handling and processing or vented through the barge common vent vapor stack;
- D. The initial cargo flow rate must be at a slow rate until the cargo loading turbulence subsides in all the cargo tanks.
- E. Where the terminal elects to load the barge and use its vapor recovery system, the transfer procedures in the manual will be followed when appropriate when loading Benzene and cargoes containing 0.5% Benzene by volume.
- F. Gauging or measurements of the cargo in each cargo tank must be accomplished through restricted gauging devices, with the gauging tubes caps tightly fitted after use to prevent vapor loss;

- G. Where samples must be taken, the personnel involved in sampling must wear full-faced respirators, protective clothing, rubber gloves and boots for their protection;
- H. A second person must maintain communication with the one entering the regulated area, or keep that individual in sight;
- I. All respirators must be approved by the Mine, Safety & Health Administration (MSHA) and NIOSH with filter elements approved for organic vapors or Benzene;
- J. Kirby Inland Marine, Inc. shall provide its employees with appropriate respirators without cost and ensure that the respirators are properly used;
- K. Half-faced respirators must be worn while monitoring the loading of Benzene or Benzene mixture barge even under closed load conditions. The only exception to the would be when a vapor recovery system puts a vacuum on the barge cargo tanks during the transfer;
- L. Full-faced respirators, protective clothing, rubber gloves and boots must be used during all cargo and vent hose hookups and disconnections, and any topside maintenance where exposure to Benzene is possible;
- M. Drip pans will be stripped of all liquid that contains Benzene or residues of that product;
- N. In the event of a spill, respiratory protection and protective clothing must be worn. Prompt notification must be made to the Kirby Inland Marine, Inc. office in any situation where there is an uncontrolled release of cargo;
- O. If the attending towboat is made up to the Benzene barge during any cargo transfer operation, the boat shall be located upwind of the barge to avoid any possible exposure to Benzene vapors to the personnel aboard;
- P. Remove and discard respirator organic vapor cartridges after each watch or when you detect the odor or taste of Benzene through your mask.

For a full explanation of cargo handling procedures involving Benzene and Benzene mixtures, the Tankerman (Person-In-Charge) should consult Kirby's Standard Operating Procedures E1.010, E1.020, and E8.010.

5.3 U.S.C.G Safety Data Information – Benzene

5.3(a) Substance Identification

A. **Substance:** Benzene

B. **Performance standard exposure limits:**

1. **Airborne:** The maximum time weighted average (TWA) exposure limit is one part of Benzene vapor per million parts of air (one PPM) for an eight hour workday and the maximum short-term exposure limit (STEL) is five ppm for any 15 minute period.
2. **Dermal:** Eye contact must be prevented and skin contact with liquid Benzene must be limited.
3. **Appearance and odor:** Benzene is a clear, colorless liquid with a sweet odor. The odor of Benzene does not provide adequate warning of its hazard.

5.3(b) Health Hazard Data

A. Ways in which Benzene affects your health: Benzene can affect your health if you inhale it or if it comes into contact with your skin or eyes. Benzene is also harmful if you swallow it.

B. Effects of Overexposure:

1. **Short-term (acute) over exposure:** If you are over exposed to high concentrations of Benzene, well above the level where its odor is first recognizable, you may feel breathlessness, irritable, euphoric or giddy and you may experience irritation in your eye, nose, and respiratory tract. You may develop a headache, feel dizzy, nauseated, or intoxicated. Severe exposure may lead to convulsions and loss of consciousness.

2. **Long-term (chronic) exposure:** Repeated or prolonged exposure to Benzene, even at relatively low concentrations, may result in various blood disorders ranging from anemia to leukemia, an irreversible fatal disease. Many blood disorders associated with Benzene exposure may occur without symptoms.

5.3(c) Protective Clothing and Equipment

- A. **Respirators:** Respirators are required for those operations in which engineering controls or work controls are not feasible for reducing exposure to the permissible level or are not chosen as the method of complying with the performance standard. If respirators are worn they must have joint Marine Safety and Healthy (NIOSH) seal of approval. Cartridges or canisters must be replaced before the end of their service life, or the end of the shift, whichever occurs first. If you experience difficult breathing while wearing a respiratory, you may request a positive pressure respirator from your employer. You must be thoroughly trained to use the assigned respirator, and the training will be provided by your employer.
- B. **Protective clothing:** You must wear appropriate protective clothing (such as boots, gloves, sleeves, and aprons) over any parts of your body that could be exposed to liquid Benzene.
- C. **Eye and face protection:** You must wear appropriate splash-proof safety goggles if it is possible that Benzene may get into your eyes. In addition, you must wear a face shield if your face could be splashed with Benzene liquid.

5.3(d) Emergency and First Aid Procedures

- A. **Eye and face exposures:** If Benzene is splashed in your eyes, wash it out immediately with large amounts of water. If irritation persists or vision appears to be affected, see a doctor as soon as possible.
- B. **Skin exposure:** If Benzene is spilled on your clothing or skin, remove the contaminated clothing and wash the exposed skin with large amounts of water and soap immediately. Wash contaminated clothing before you wear it again.

- C. **Breathing:** If you or any other person breathes in large amounts of Benzene, get the exposed person to fresh air at once. Apply resuscitation if breathing has stopped. Call for medical assistance or a doctor as soon as possible. Never enter any vessel or confined space where the Benzene concentration might be high without proper safety equipment and with at least one other person present who will stay outside. A life line should be used.

- D. **Swallowing:** If Benzene has been swallowed and the subject is conscious, do not induce vomiting. Call for medical assistance or a doctor immediately.

5.3(e) Medical Requirements

If you will be exposed to Benzene at a concentration at or above 0.5 ppm as an eight hour time-weighted average or have been exposed at or above 10 ppm in the past while employed by your current employer, your employer may be required by CFR §197.560 to provide a medical examination and history and laboratory tests. These tests must be provided without cost to you. In addition, if you are accidentally exposed to Benzene (either by ingestion, inhalation, or skin/eye contact) under emergency conditions known or suspected to constitute a toxic exposure to Benzene, your employer is required to make special laboratory tests available to you.

5.3(f) Observation of Monitoring

The employer is required to conduct monitoring that is representative of your exposure to Benzene, and you or your designated representative are entitled to observe the monitoring procedure. You are entitled to observe the steps taken in the measurement procedure and to record the results obtained. When the monitoring procedure is taking place in an area where respirators or personal protective clothing and equipment are required to be worn, you must wear the protective clothing and equipment. (See 46 CFR §197.575).