

STARBOARD

- | | | | |
|-----|----------------------|-----|---------------------------------|
| NO | DESCRIPTION | NO | DESCRIPTION |
| 1C | CARGO TANK VALVE | 12C | BURP VALVE RETURN TO CARGO TANK |
| 2C | LOAD VALVE | 13C | CARGO PIPING BLOCK VALVE |
| 3C | MASTER SUCTION VALVE | 19C | CARGO HEADER |
| 4C | DISCHARGE VALVE | 24C | FLOW INDICATOR |
| 5C | HEADER VALVE | 30C | CARGO PIPELINE |
| 6C | SALVAGE VALVE | 37C | CARGO DROP |
| 8C | RELIEF VALVE | — | — ABOVE DECK PIPING |
| 9C | CHECK VALVE | --- | --- BELOW DECK PIPING |
| 10C | BURP VALVE | | |
| 11C | BLEED OFF VALVE | | |

NOTE 1: CONTAINMENT P/S

REV.	DATE	BY	CHK	APP	REVISION DESCRIPTION
3	03/06/15	SC	DDA		REVISED PER CLIENT COMMENTS
2	11/07/13	DCB	DDA		MOVED 13C
1	03/08/11	DCB	DDA		REVISED TANK CAPACITY
A	01/07/11	BAG	RB	OF	FOR APPROVAL

KIRBY INLAND MARINE 

**CARGO
PIPING FLOW DIAGRAM**

SCALE: NONE
PAGE: 1 OF 3

KIRBY 28167

REV. **3**

TRINITY

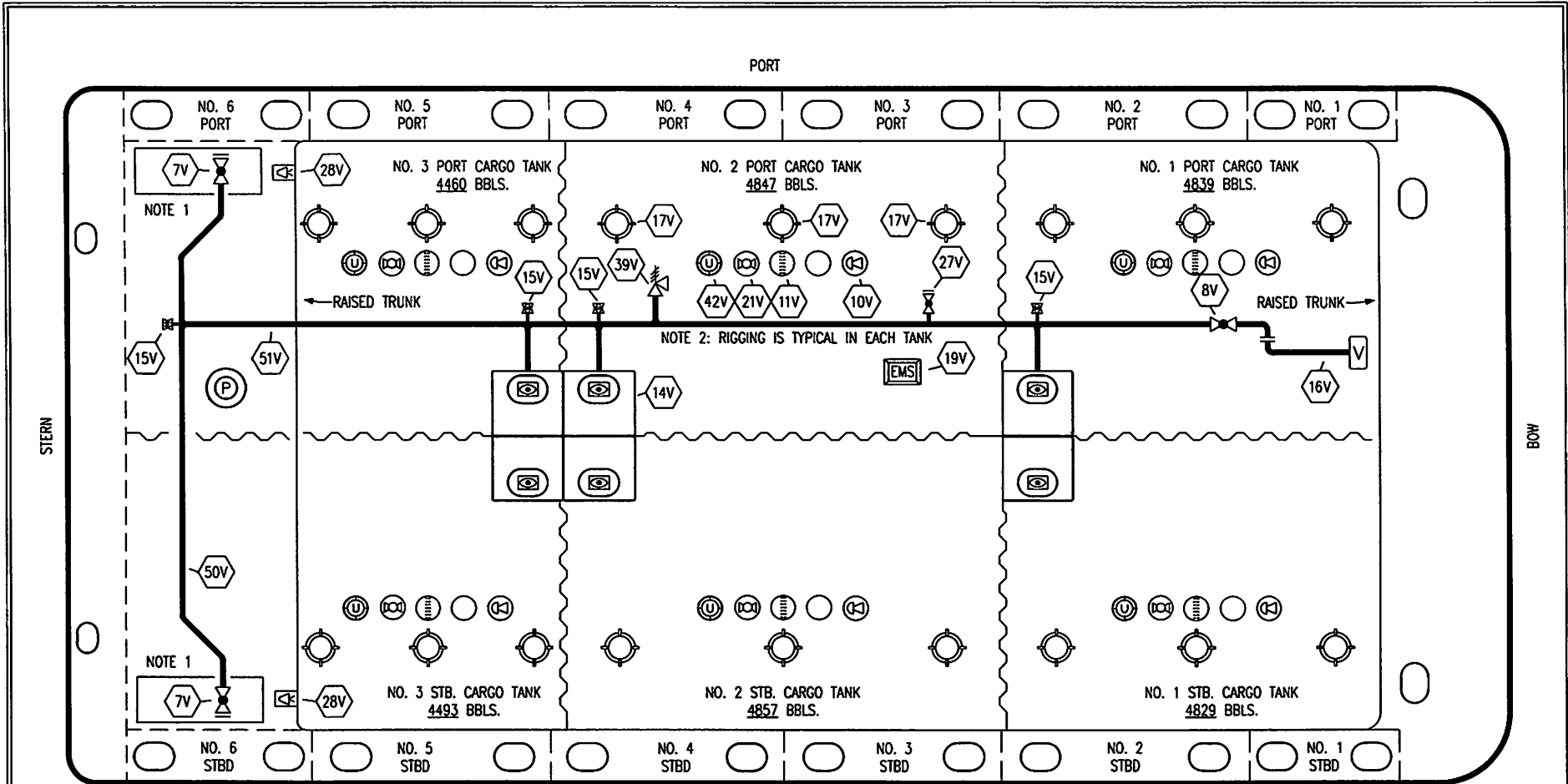

NO	DESCRIPTION	NO	DESCRIPTION
7V	8" HEADER VALVE	21V	2" HERMETIC GAUGE
8V	8" VENT STACK VALVE	27V	1/4" TEST CONNECTION VALVE
10V	8" HIGH LEVEL/OVERFILL ALARM	28V	DOCK CONNECTION ALARM
11V	8" 1-METER STICK GAUGE	38V	8" VAPOR PENETRATION (⊙)
14V	6" SIGHT GLASS W/GAUGE TREE	39V	PRESS/VAC RELIEF VALVE
15V	2" INSPECTION PORT	42V	8" ULLAGE HATCH
16V	8" VAPOR VENT STACK	50V	8" VAPOR HEADER
17V	14" BUTTERWORTH	51V	8" VAPOR PIPELINE
18V	2" RESTRICTIVE GAUGE TUBE		
19V	EMERGENCY ENGINE SHUT DOWN	—	ABOVE DECK PIPING

NOTE 1: CONTAINMENT P/S
 NOTE 2: RIGGING IS TYPICAL IN EACH TANK

REV.	DATE	BY	CHK	APP	REVISION DESCRIPTION
2	03/06/15	SC	DDA		REVISED PER CLIENT COMMENTS
1	04/12/11	JN	DDA		REVISED TANK CAPACITY
A	01/07/11	BAG	RB	OF	FOR APPROVAL

TRINITY

KIRBY INLAND MARINE

VAPOR PIPING FLOW DIAGRAM

KIRBY 28167

SCALE: NONE
 PAGE: 2 OF 3
 REV. **2**

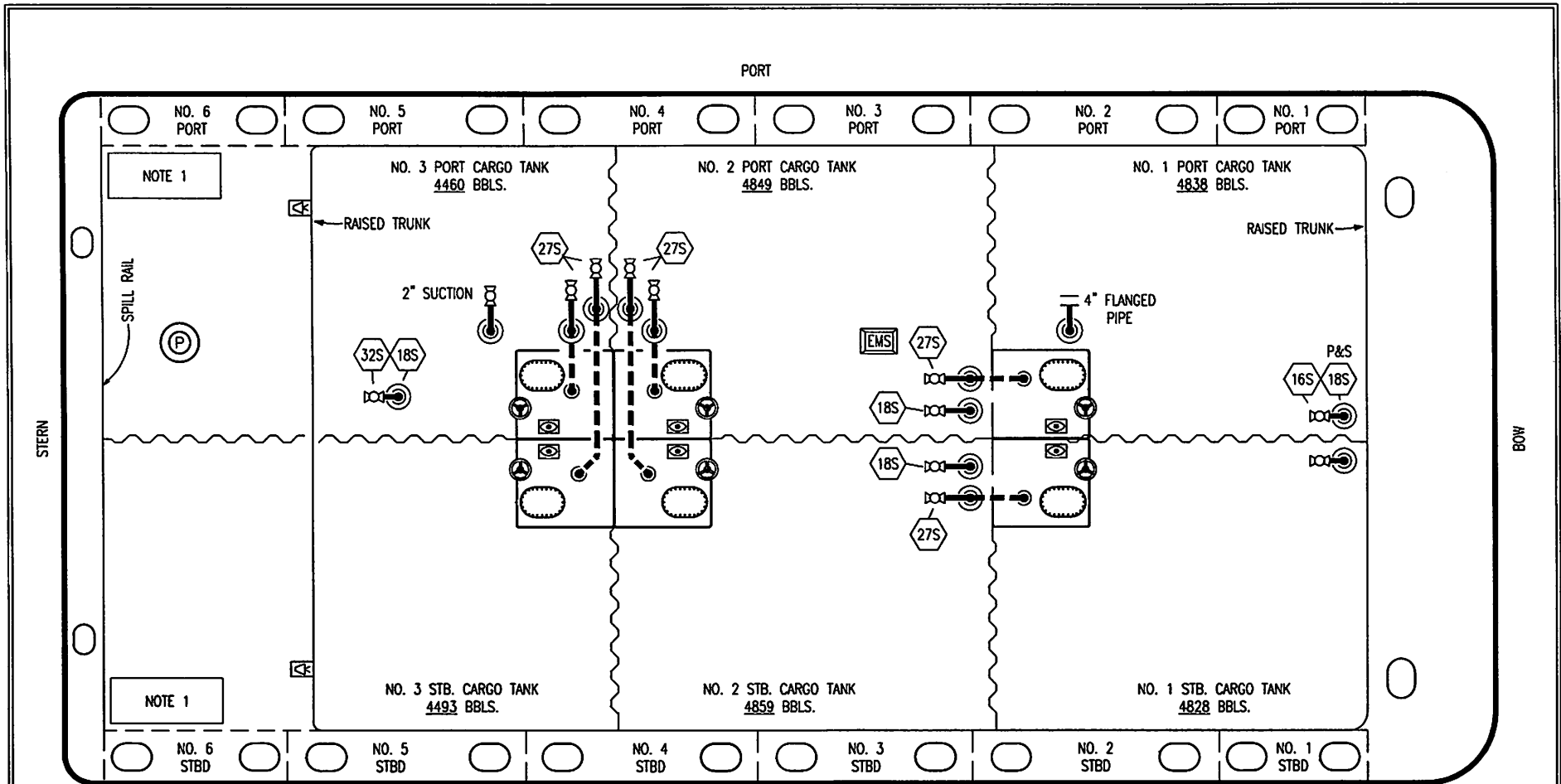

NOTE 1

NOTE 1

- NO DESCRIPTION
- 16S REMOTE SUCTION CONNECTION
- 18S TYP. STRIPPING DROP
- 27S SUMP SUCTION VALVE
- ABOVE DECK PIPING
- - - BELOW DECK PIPING
- EMS EMERGENCY SHUT DOWN
- P DEEP WELL PUMP

NOTE 1: CONTAINMENT P/S

REV.	DATE	BY	CHK	APP	REVISION DESCRIPTION
3	03/06/15	SC	DDA		REVISED PER CLIENT COMMENTS
2	11/07/13	DCB	DDA		REVISED PIPING
1	03/01/11	DCB	DDA		REVISED CARGO CAPACITY
0	10/14/11	JN	DDA		ISSUED FOR APPROVAL

KIRBY INLAND MARINE

**STRIPPING
PIPING FLOW DIAGRAM**

SCALE: NONE
PAGE: 3 OF 3

KIRBY 28167 REV. **3**

TRINITY