

PORT

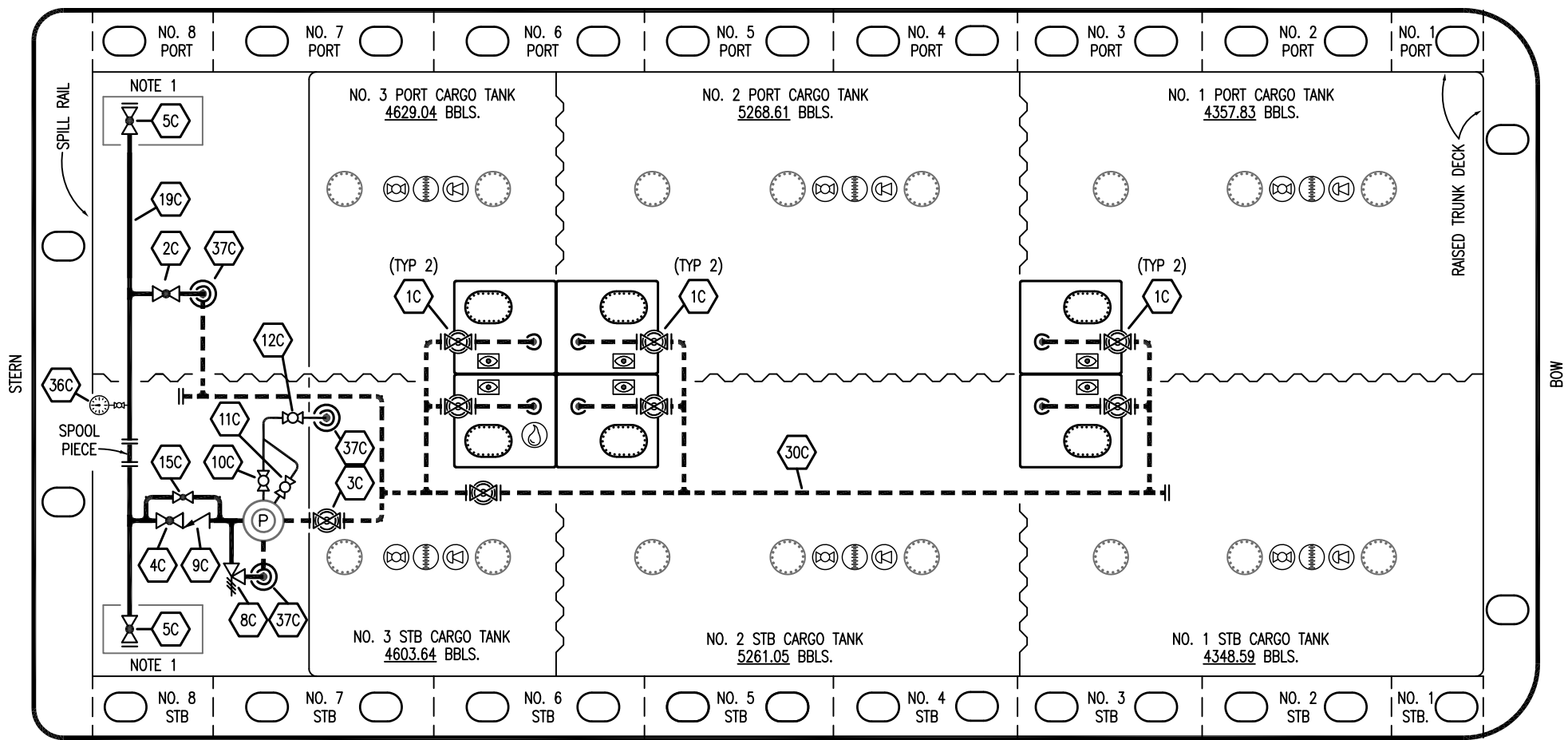

STARBOARD

- | | | | |
|-----------|--------------------------|-----------|---------------------------------|
| NO | DESCRIPTION | NO | DESCRIPTION |
| 1C | 8" CARGO TANK VALVE | 12C | BURP VALVE RETURN TO CARGO TANK |
| 2C | 8" LOAD VALVE | 15C | 2" CHECK BYPASS VALVE |
| 3C | 12" MASTER SUCTION VALVE | 19C | 8" CARGO HEADER |
| 4C | 8" DISCHARGE VALVE | 30C | 12" CARGO PIPELINE |
| 5C | 8" HEADER VALVE | 36C | PRESSURE GAUGE |
| 8C | 6" RELIEF VALVE | 37C | CARGO DROP |
| 9C | 8" CHECK VALVE | — | — ABOVE DECK PIPING |
| 10C | BURP VALVE | - - - | BELOW DECK PIPING |
| 11C | BLEED OFF VALVE | | |

NOTE 1: CONTAINMENT P/S

WEST GULF MARINE

REV.	DATE	BY	CHK	APP	REVISION DESCRIPTION
3	12/12/22	MRV	DDA	FIX	REVISED PER CLIENT COMMENTS
2	10/28/21	MRV	DDA	DAW	REVISED PER CLIENT COMMENTS
1	10/11/17	WFB	DDA		REVISED PER CLIENT COMMENTS
0	02/03/12	DCB	DDA		ISSUED FOR APPROVAL

KIRBY INLAND MARINE

CARGO

PIPING FLOW DIAGRAM

KIRBY 28149

REV. 3

SCALE: NONE
PAGE: 1 OF 3

PORT

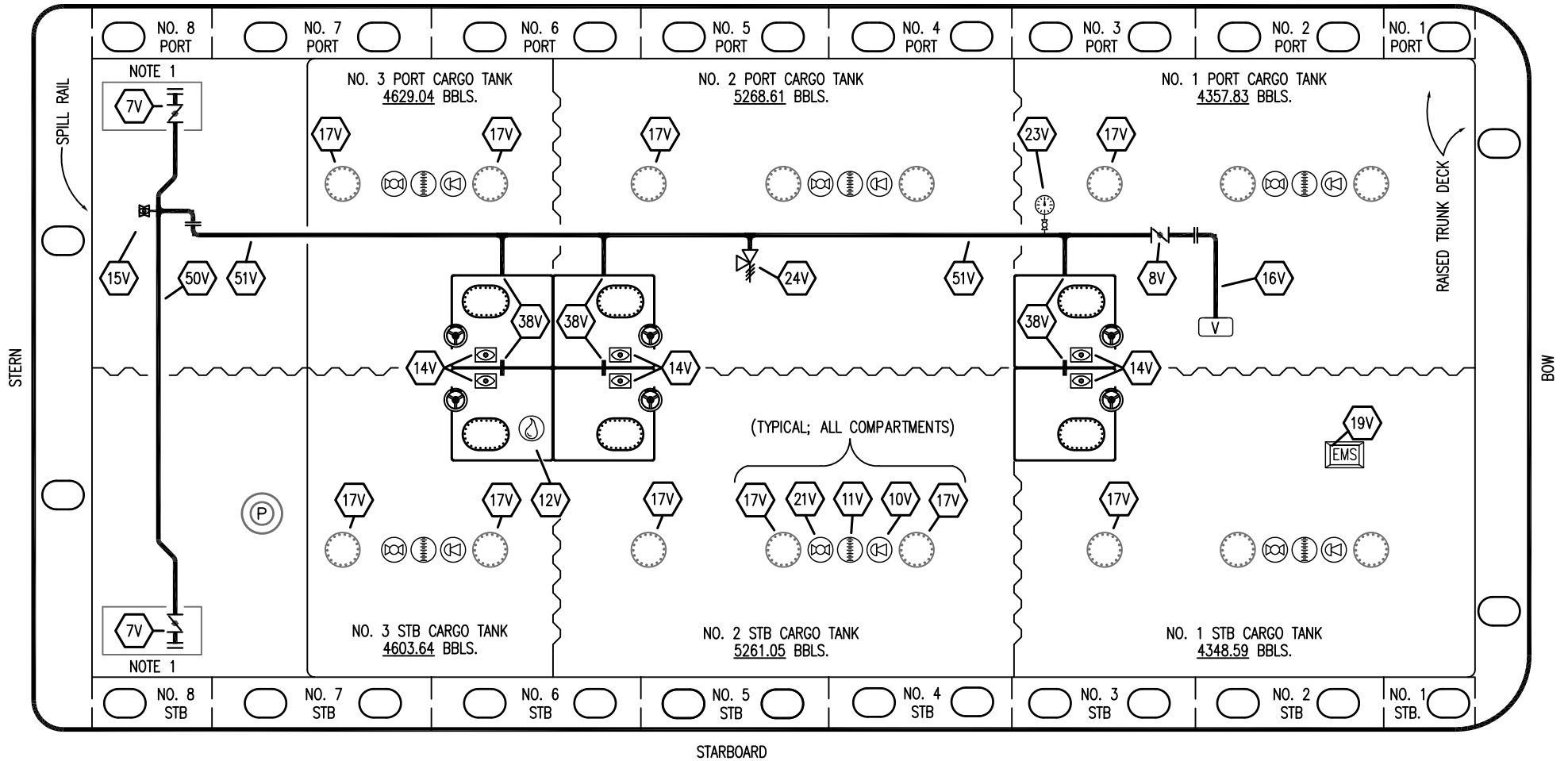

- | | | | |
|-----|---------------------------|-----|---|
| NO | DESCRIPTION | NO | DESCRIPTION |
| 7V | 8" HEADER VALVE | 23V | GAUGE |
| 8V | 8" VENT STACK VALVE | 24V | 6" PRESSURE RELIEF VALVE, HIGH VELOCITY |
| 10V | HIGH LEVEL/OVERFILL ALARM | 38V | 10" VAPOR PENETRATION |
| 11V | 1 METER GAUGE STICK | 50V | VAPOR HEADER |
| 12V | 2" HERMETIC SAMPLE | 51V | VAPOR PIPELINE |
| 14V | 8" SIGHT GLASS | — | ABOVE DECK PIPING |
| 15V | INSPECTION PORT | | |
| 16V | 8" VAPOR VENT STACK | | |
| 19V | EMERGENCY SHUTDOWN SYSTEM | | |
| 21V | HERMETIC GAUGE | | |
| 17V | 20" BUTTERWORTH | | |

NOTE 1: CONTAINMENT P/S

WEST GULF MARINE

REV.	DATE	BY	CHK	APP	REVISION DESCRIPTION
3	12/12/22	MRV	DDA	FIX	REVISED PER CLIENT COMMENTS
2	10/28/21	MRV	DDA	DAW	REVISED PER CLIENT COMMENTS
1	05/07/14	DDA	DDA	OF	REVISED PER CLIENT COMMENTS
0	02/03/12	DCB	DDA		ISSUED FOR APPROVAL

KIRBY INLAND MARINE 

**VAPOR
PIPING FLOW DIAGRAM**

SCALE: NONE
PAGE: 2 OF 3

KIRBY 28149

REV. **3**

PORT

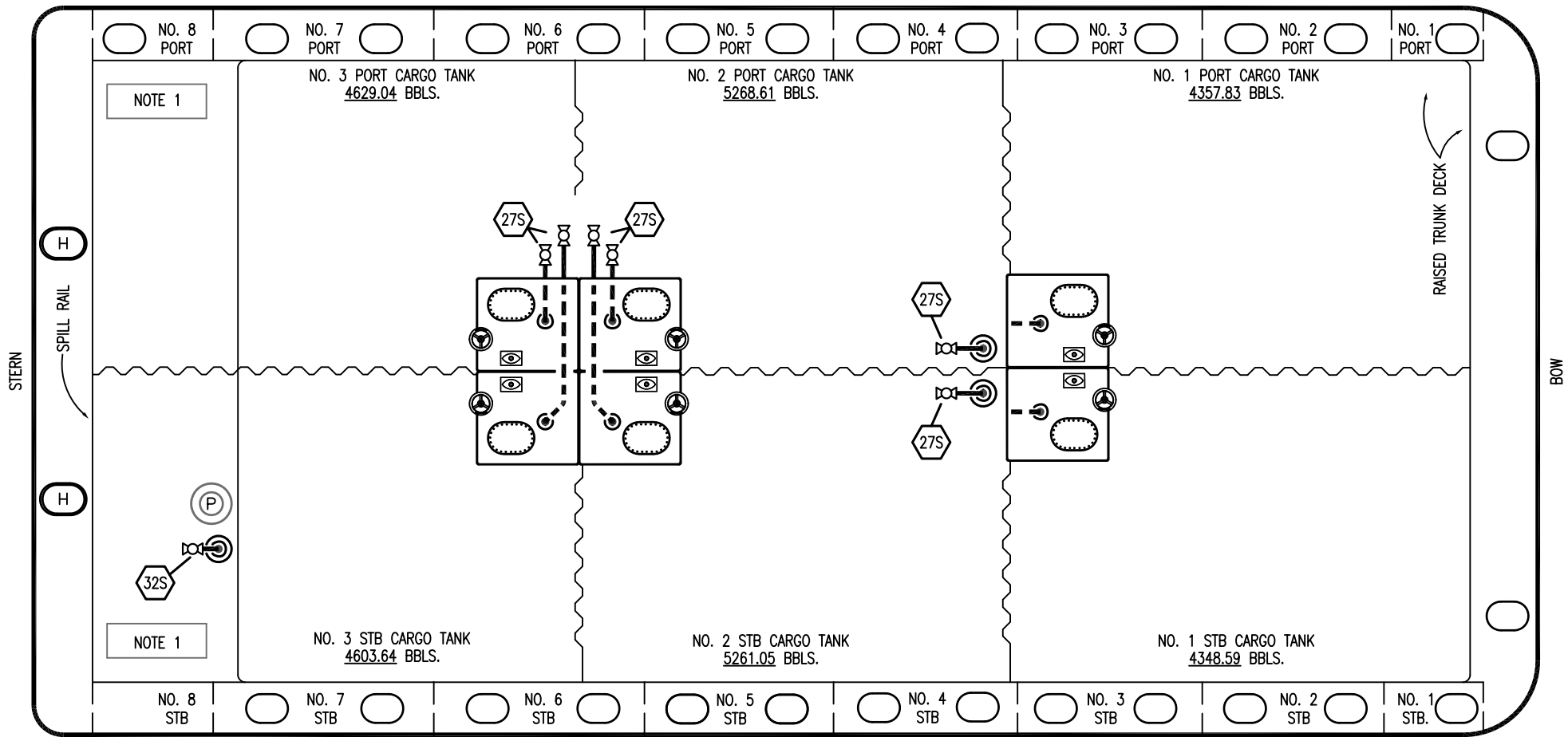

- | NO | DESCRIPTION |
|-------|--------------------------------|
| 18S | TYP. STRIPPING PENETRATION (⊙) |
| 27S | SUMP SUCTION |
| 32S | PUMP WELL PRIMER VALVE |
| 33S | PUMP WELL SUCTION |
| 40S | CARGO TANK SUCTION |
| — | ABOVE DECK PIPING |
| - - - | BELOW DECK PIPING |

NOTE 1: CONTAINMENT P/S

WEST GULF MARINE

REV.	DATE	BY	CHK	APP	REVISION DESCRIPTION
2	12/12/22	MRV	DDA	FIX	REVISED PER CLIENT COMMENTS
1	10;/28/21	MRV	DDA	DAW	REVISED PER CLIENT COMMENTS
0	02/03/12	DCB	DDA		ISSUED FOR APPROVAL

KIRBY INLAND MARINE

STRIPPING
PIPING FLOW DIAGRAM

SCALE: NONE	KIRBY 28149	REV. 1
PAGE: 3 OF 3		