

- | | | | |
|-----|--------------------------|-------|-----------------------|
| NO | DESCRIPTION | NO | DESCRIPTION |
| 1C | 8" CARGO TANK VALVE | 15C | 2" CHECK BYPASS VALVE |
| 2C | 8" LOAD VALVE | 19C | 8" CARGO HEADER |
| 3C | 12" MASTER SUCTION VALVE | 24C | FLOW INDICATOR |
| 4C | 8" DISCHARGE VALVE | 30C | 12" CARGO PIPELINE |
| 5C | 8" HEADER VALVE | 37C | CARGO DROP |
| 8C | 6" RELIEF VALVE | — | — ABOVE DECK PIPING |
| 9C | 8" CHECK VALVE | - - - | BELOW DECK PIPING |
| 10C | BURP VALVE | | |

NOTE 1: CONTAINMENT P/S

WEST GULF MARINE

REV.	DATE	BY	CHK	APP	REVISION DESCRIPTION
1	06/06/17	WFB	DDA		REVISED PER CLIENT COMMENTS
0	06/29/11	JN	DDA	OF	APPROVED



KIRBY INLAND MARINE

CARGO

PIPING FLOW DIAGRAM

KIRBY 28144

SCALE: NONE

PAGE: 1 OF 3

REV. **1**

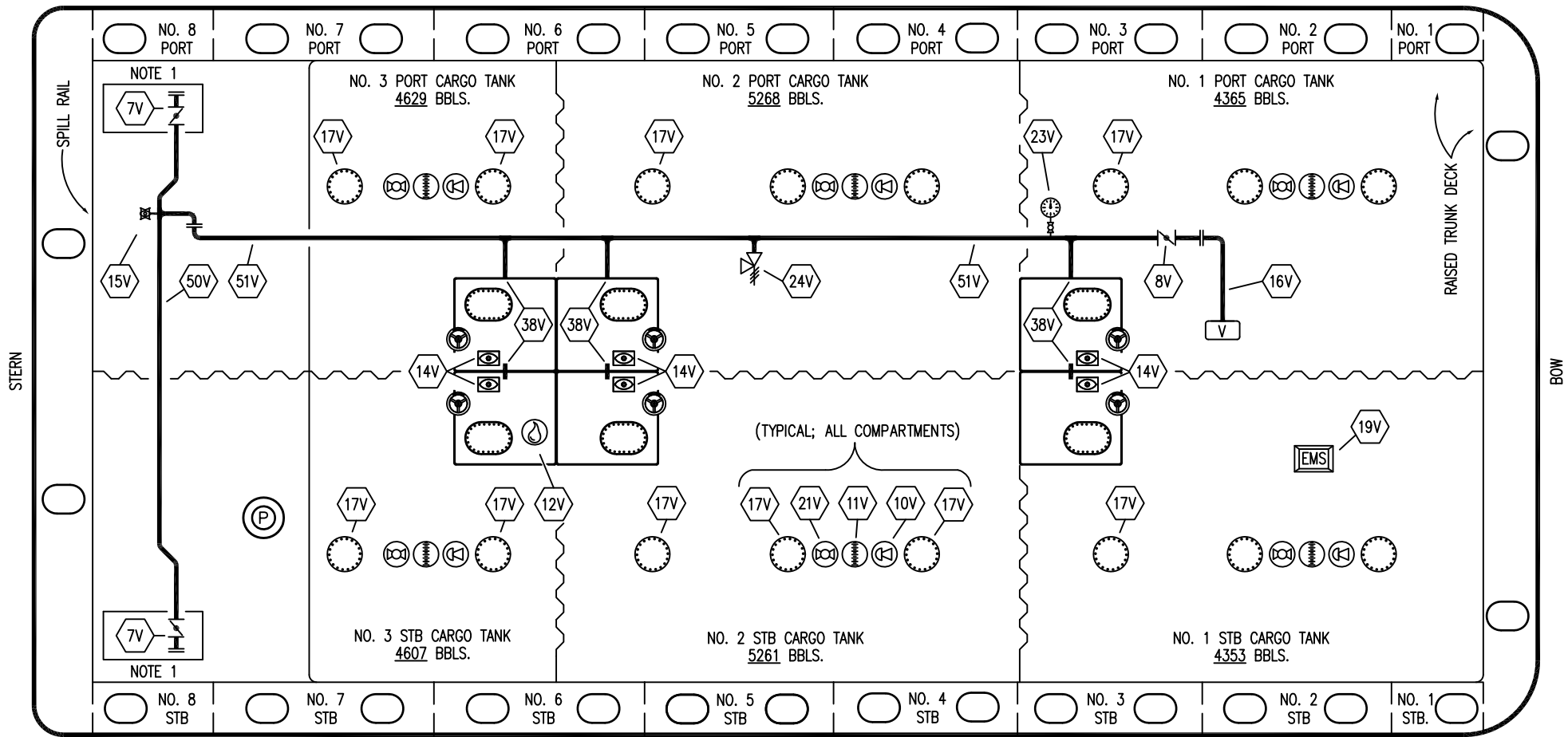

- | | | | |
|-----|---------------------------|-----|---|
| NO | DESCRIPTION | NO | DESCRIPTION |
| 7V | 8" HEADER VALVE | 23V | GAUGE |
| 8V | 8" VENT STACK VALVE | 24V | 6" PRESSURE RELIEF VALVE, HIGH VELOCITY |
| 10V | HIGH LEVEL/OVERFILL ALARM | 38V | 10" VAPOR PENETRATION |
| 11V | 1 METER GAUGE STICK | 50V | VAPOR HEADER |
| 12V | 2" HERMETIC SAMPLE | 51V | VAPOR PIPELINE |
| 14V | 8" SIGHT GLASS | — | ABOVE DECK PIPING |
| 15V | INSPECTION PORT | | |
| 16V | 8" VAPOR VENT STACK | | |
| 19V | EMERGENCY SHUTDOWN SYSTEM | | |
| 21V | HERMETIC GAUGE | | |
| 17V | 20" BUTTERWORTH | | |

NOTE 1: CONTAINMENT P/S

WEST GULF MARINE



KIRBY INLAND MARINE

VAPOR PIPING FLOW DIAGRAM

KIRBY 28144

1	05/07/14	DDA	DDA	OF	REVISED PER CLIENT COMMENTS				
0	06/29/11	JN	DDA	OF	APPROVED				
REV.	DATE	BY	CHK	APP	REVISION	DESCRIPTION	SCALE: NONE	PAGE: 2 OF 3	REV. 1

