

| NO | SIZE | DESCRIPTION | NO | SIZE | DESCRIPTION |
|-----|------|-----------------------------------|------|--------|----------------------------|
| 1C | 8" | CARGO TANK VALVE | 19C | 8" | CARGO HEADER |
| 2C | 10" | LOAD VALVE | 22C | 19" | BUTTERWORTH |
| 3C | 12" | MASTER SUCTION VALVE | 25C | 10"x8" | ECCENTRIC REDUCER |
| 4C | 10" | DISCHARGE VALVE | 27C | 4" | DRIP PAN DRAIN VALVE |
| 5C | 10" | HEADER VALVE | 28C | 6" | HIGH LOAD VALVE |
| 6C | 10" | SALVAGE VALVE | 11V | | GAUGE STICK (LENGTH) |
| 8C | 6" | RELIEF VALVE | 18V | | RESTRICTIVE GAUGE TUBE |
| 9Ca | 8" | CHECK VALVE | 30V | | THERMAL WELL WITH PIPE CAP |
| 9Cb | 1" | CHECK VALVE | 38Ca | | DEEPWELL DRAIN VALVE |
| 15C | 2" | BYPASS VALVE (AROUND CHECK VALVE) | 38Cb | 1" | GATE VALVE |
| 16C | | DISCHARGE PRESSURE GAUGE | 38Cd | 1" | SPRING VALVE |

NOTE 1: 6 BARREL DRIP PAN
 NOTE 2: PICKLING LINE
 ABOVE DECK PIPING ———
 BELOW DECK PIPING - - -

| REV. | DATE | BY | CHK | APP | REVISION DESCRIPTION |
|------|----------|-----|-----|-----|-----------------------------|
| 1 | 05/07/14 | DDA | DDA | OF | REVISED PER CLIENT COMMENTS |
| 0 | 03/16/09 | WK | RB | OF | APPROVED |

TRINITY MARINE

KIRBY INLAND MARINE

CARGO

PIPING FLOW DIAGRAM

KIRBY 27754

REV. **1**

SCALE: NONE
 PAGE: 1 OF 3

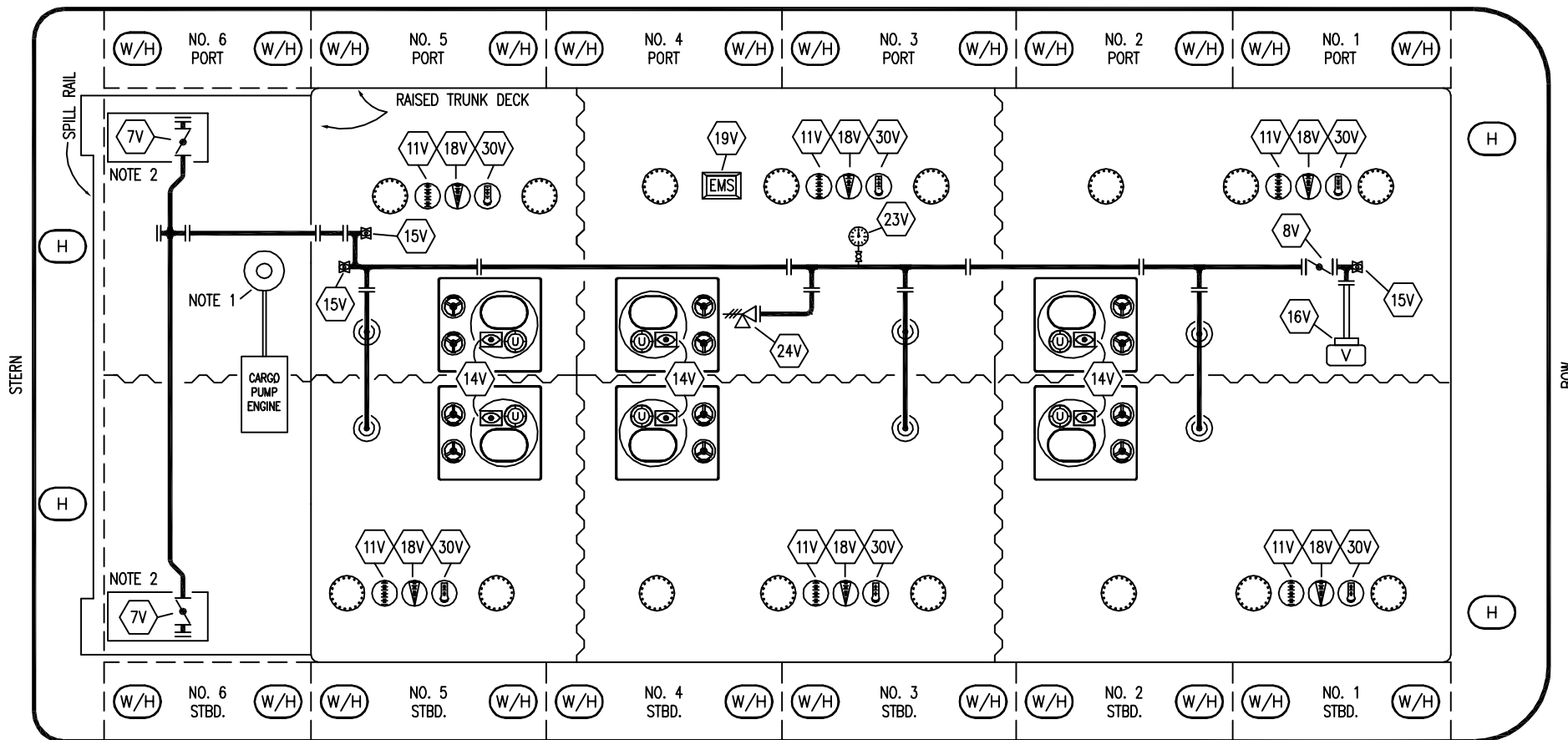

| NO | SIZE | DESCRIPTION | NO | SIZE | DESCRIPTION |
|-----|------|---------------------------|-----|------|----------------------------|
| 7V | 8" | HEADER VALVE | 24V | 6" | PRESSURE RELIEF VALVE |
| 8V | 8" | VENT STACK VALVE | 30V | 2" | THERMAL WELL WITH PIPE CAP |
| 11V | | GAUGE STICK (LENGTH) | | | |
| 14V | | SIGHT GLASS | | | |
| 15V | | INSPECTION PORT | | | |
| 16V | 8" | VAPOR VENT STACK | | | |
| 18V | | RESTRICTIVE GAUGE TUBE | | | |
| 19V | | EMERGENCY SHUTDOWN SYSTEM | | | |
| 23V | | PRESSURE GAUGE | | | |

NOTE 1: DEEPWELL PUMP
 NOTE 2: 6 BARREL DRIP PAN
 ABOVE DECK PIPING ———

TRINITY MARINE

| | | | | | | | |
|------|----------|----|-----|-----|----------------------|--|--------------------|
| | | | | | | KIRBY INLAND MARINE  | |
| | | | | | | | |
| 0 | 03/09/09 | WK | RB | OF | APPROVED | SCALE: NONE | KIRBY 27754 |
| REV. | DATE | BY | CHK | APP | REVISION DESCRIPTION | PAGE: 2 OF 3 | |

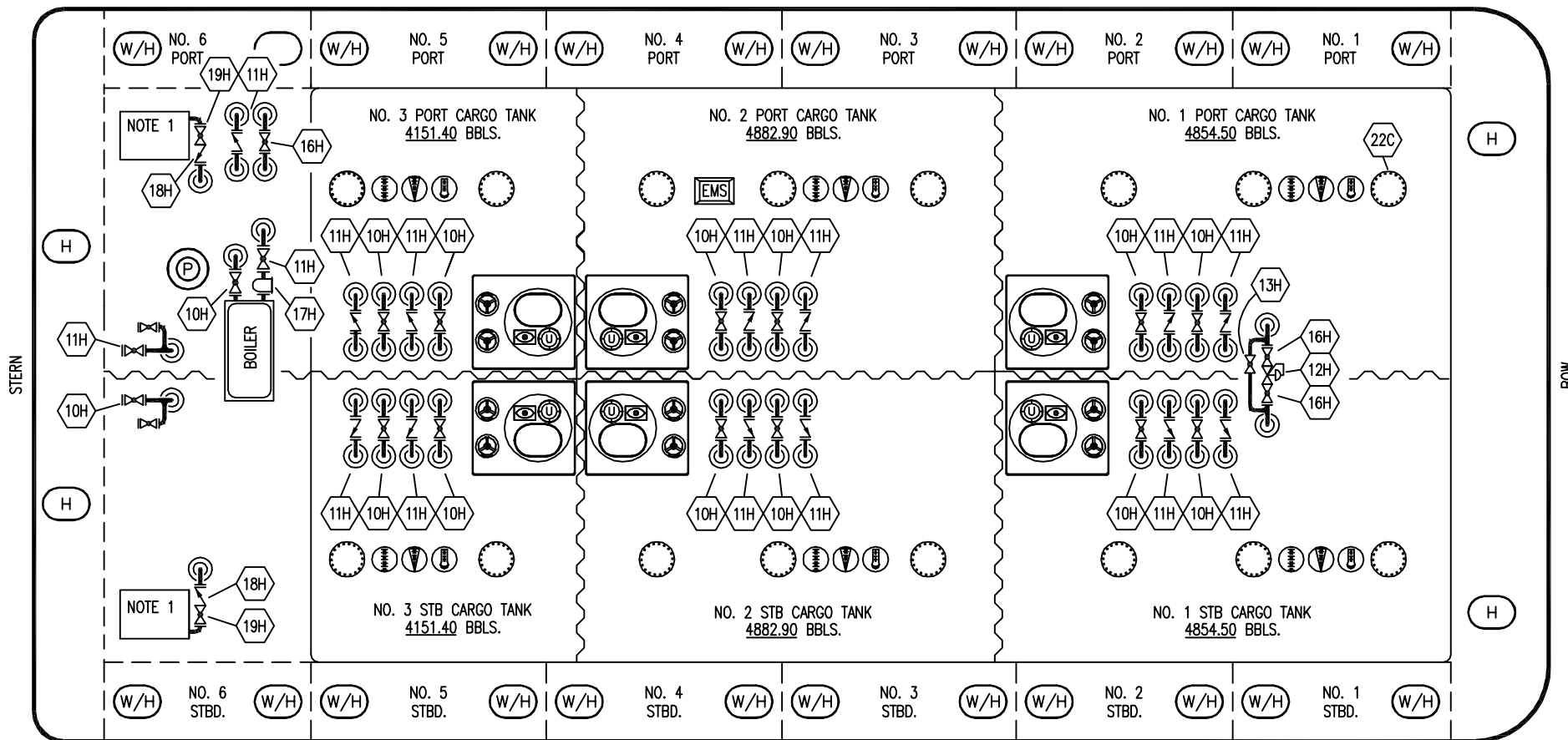

- | NO | DESCRIPTION |
|-----|----------------------|
| 10H | SUPPLY VALVE |
| 11H | RETURN |
| 12H | PRESSURE REGULATOR |
| 13H | BY-PASS |
| 16H | ISOLATION VALVE |
| 17H | BASKET STRAINER |
| 18H | CHECK VALVE |
| 19H | DRIP PAN DRAIN VALVE |
- ABOVE DECK PIPING

NOTE 1: 6 BARREL DRIP PAN

TRINITY MARINE

| | | | | | | | | |
|------|----------|----|-----|-----|----------------------|----------------------------|--|---|
| | | | | | | KIRBY INLAND MARINE | |  |
| | | | | | | HOT OIL | | |
| | | | | | | PIPING FLOW DIAGRAM | | |
| | | | | | | KIRBY 27754 | | REV. 0 |
| 0 | 03/16/09 | WK | RB | OF | APPROVED | SCALE: NONE | | |
| REV. | DATE | BY | CHK | APP | REVISION DESCRIPTION | PAGE: 3 of 3 | | |