

PORT

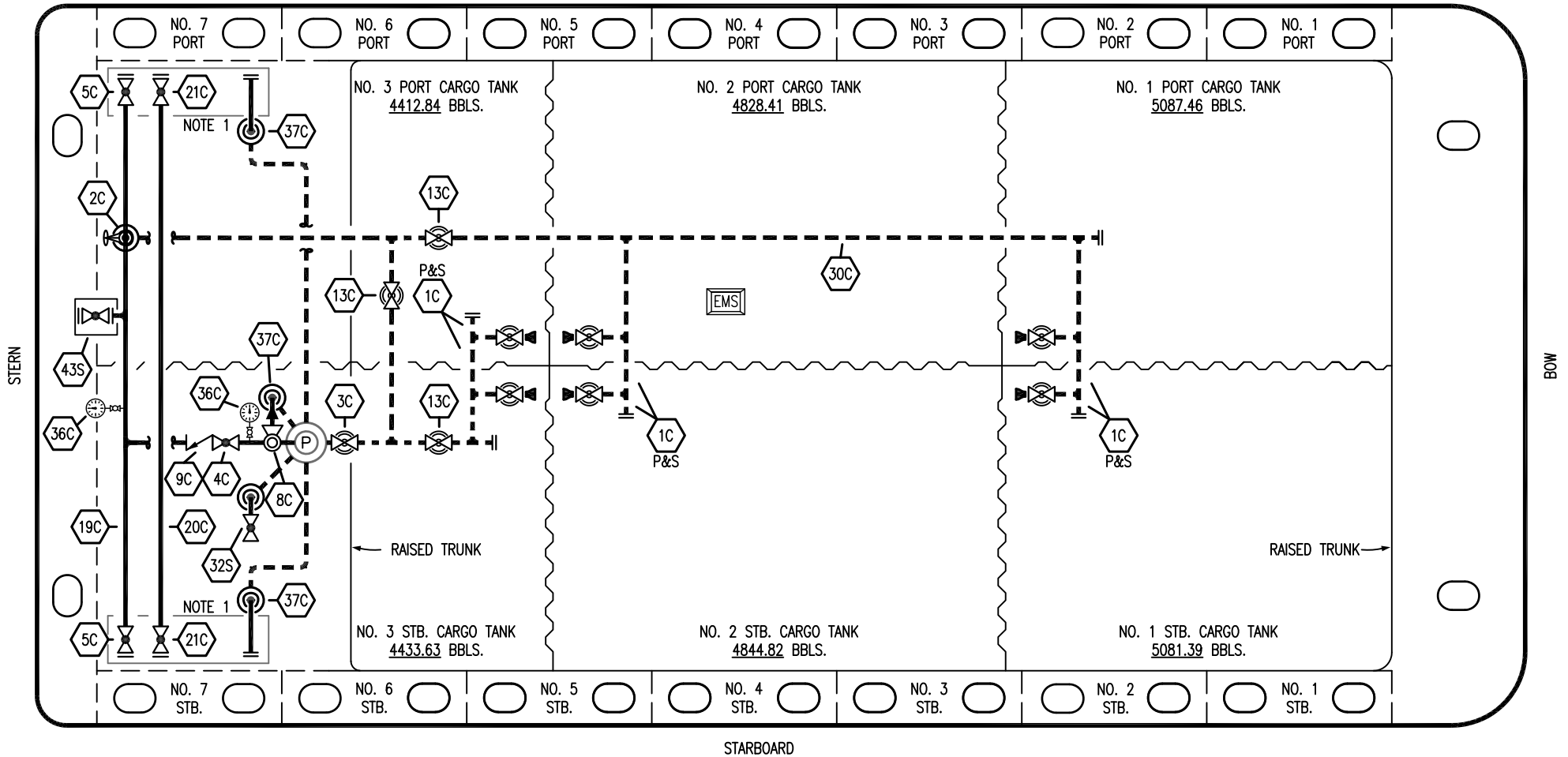

NO	DESCRIPTION	NO	DESCRIPTION
1C	CARGO TANK VALVE	20C	DUMMY HEADER PIPING
2C	LOAD VALVE	21C	DUMMY HEADER VALVE
3C	MASTER SUCTION VALVE	30C	CARGO PIPELINE
4C	DISCHARGE VALVE	32S	DEEPWELL STRIPPING VALVE SUCTION
5C	HEADER VALVE	36C	PRESSURE GAUGE
8C	RELIEF VALVE	37C	CARGO DROP
9C	CHECK VALVE	43S	STERN HEADER VALVE
13C	CARGO PIPING BLOCK VALVE	—	— ABOVE DECK PIPING
19C	CARGO HEADER	- - -	- - - BELOW DECK PIPING

NOTE 1: CONTAINMENT P/S

REV.	DATE	BY	CHK	APP	REVISION DESCRIPTION
3	12/07/22	MRV	DDA	CW	REVISED PER CLIENT COMMENTS
2	11/12/19	NRB	DDA		REVISED PER CLIENT COMMENTS
1	08/20/19	NRB	DDA		REVISED BARGE NAME
0	02/20/19	MRV	DDA		ISSUED FOR APPROVAL

TRINITY

KIRBY INLAND MARINE

CARGO

PIPING FLOW DIAGRAM

KIRBY 27732

SCALE: NONE
PAGE: 1 OF 3

REV. 3

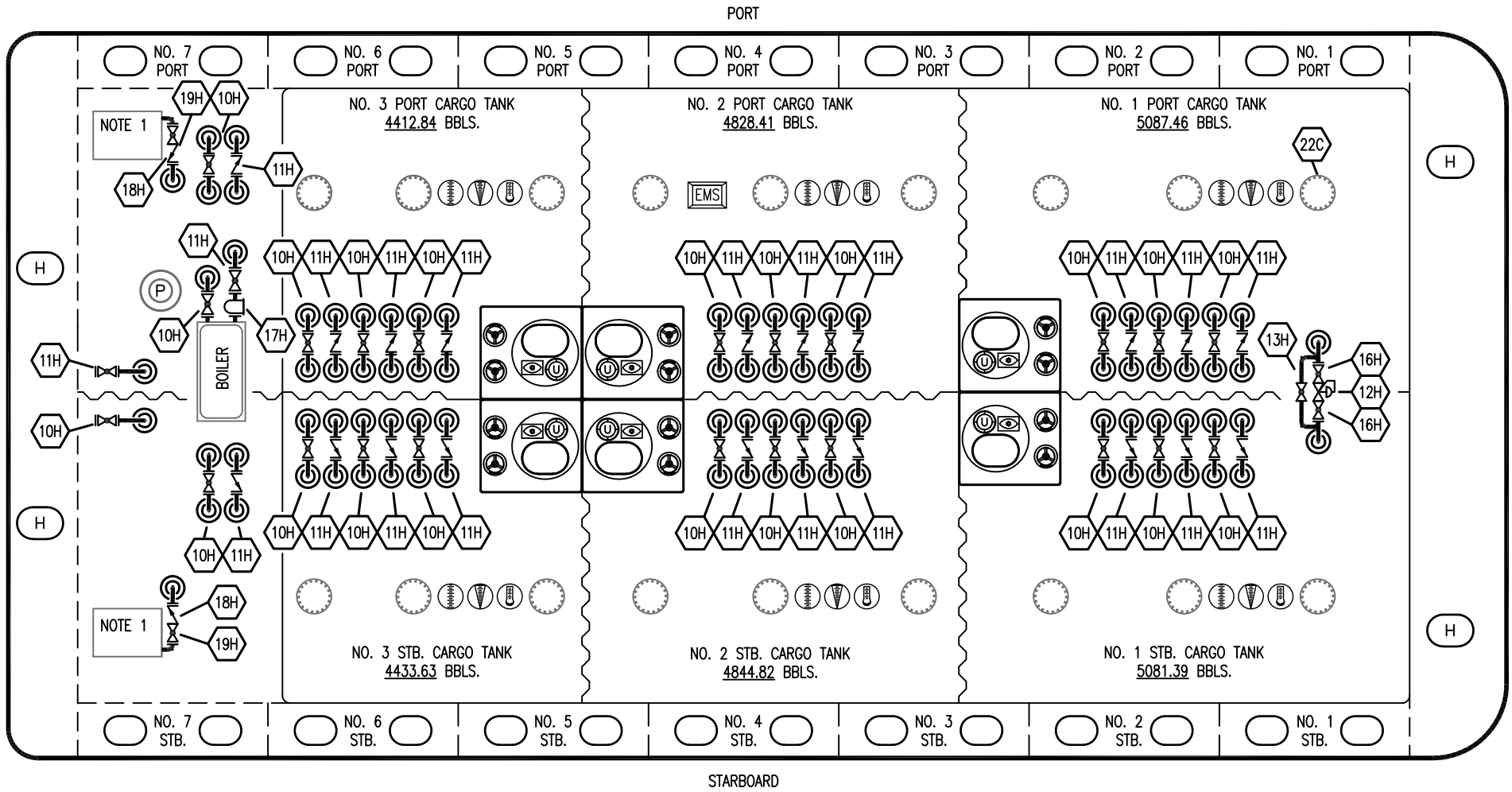

- | NO | DESCRIPTION |
|-----|----------------------|
| 10H | SUPPLY VALVE |
| 11H | RETURN |
| 12H | PRESSURE REGULATOR |
| 13H | BY-PASS |
| 16H | ISOLATION VALVE |
| 17H | BASKET STRAINER |
| 18H | CHECK VALVE |
| 19H | DRIP PAN DRAIN VALVE |
- ABOVE DECK PIPING

NOTE 1: 6 BARREL DRIP PAN

REV.	DATE	BY	CHK	APP	REVISION DESCRIPTION
2	12/07/22	MRV	DDA	CW	REVISED PER CLIENT COMMENTS
1	08/20/19	NRB	DDA		REVISED BARGE NAME
0	02/20/19	MRV	DDA		ISSUED FOR APPROVAL

KIRBY INLAND MARINE		
HOT OIL PIPING FLOW DIAGRAM		
SCALE: NONE	KIRBY 27732	
PAGE: 2 of 3	REV. 2	

TRINITY

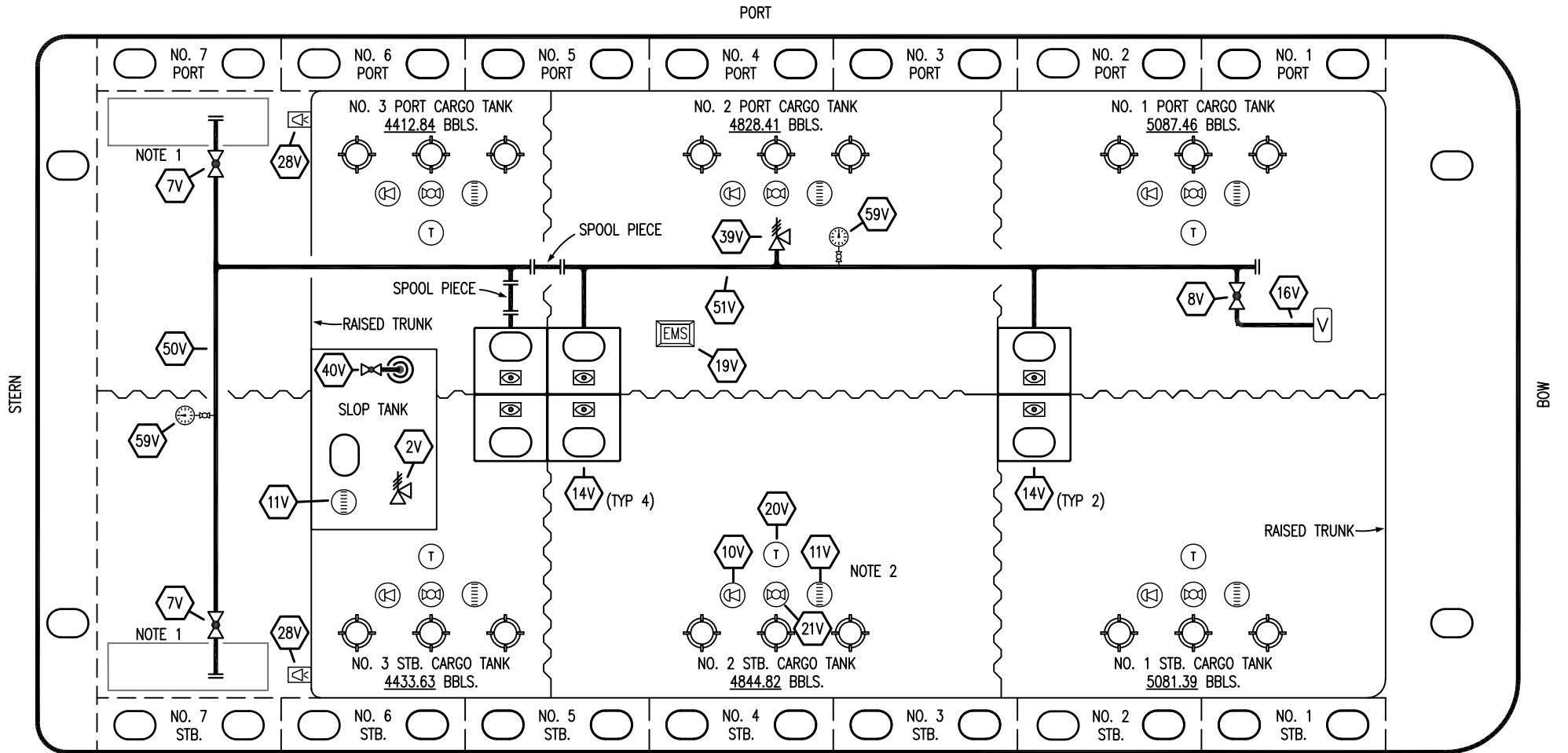

NO	DESCRIPTION
2V	PRESS/VAC SLOP TANK RELIEF
7V	HEADER VALVE
8V	VENT STACK VALVE
10V	HIGH LEVEL/OVERFILL ALARM
11V	1-METER GAUGE STICK
14V	SIGHT GLASS
16V	VAPOR VENT STACK
19V	EMERGENCY ENGINE SHUT DOWN

NO	DESCRIPTION
20V	PORTABLE TEMPERATURE DISPLAY UNIT (PTDU)
21V	HERMETIC GAUGE
28V	DOCK CONNECTION ALARM
39V	PRESSURE/VACUUM RELIEF VALVE
40V	SLOP TANK SUCTION VALVE
50V	VAPOR HEADER
51V	VAPOR PIPELINE
59V	PRESS/VAC GAUGE

— ABOVE DECK PIPING

STARBOARD

NOTE 2: TYPICAL RIGGING IN EACH TANK

NOTE 1: CONTAINMENT P/S

REV.	DATE	BY	CHK	APP	REVISION DESCRIPTION
2	12/07/22	MRV	DDA	CW	REVISED PER CLIENT COMMENTS
1	08/20/19	NRB	DDA		REVISED BARGE NAME
0	02/20/19	MRV	DDA		ISSUED FOR APPROVAL

TRINITY

KIRBY INLAND MARINE

VAPOR PIPING FLOW DIAGRAM

SCALE: NONE	KIRBY 27732	REV. 2
PAGE: 3 OF 3		