

PORT

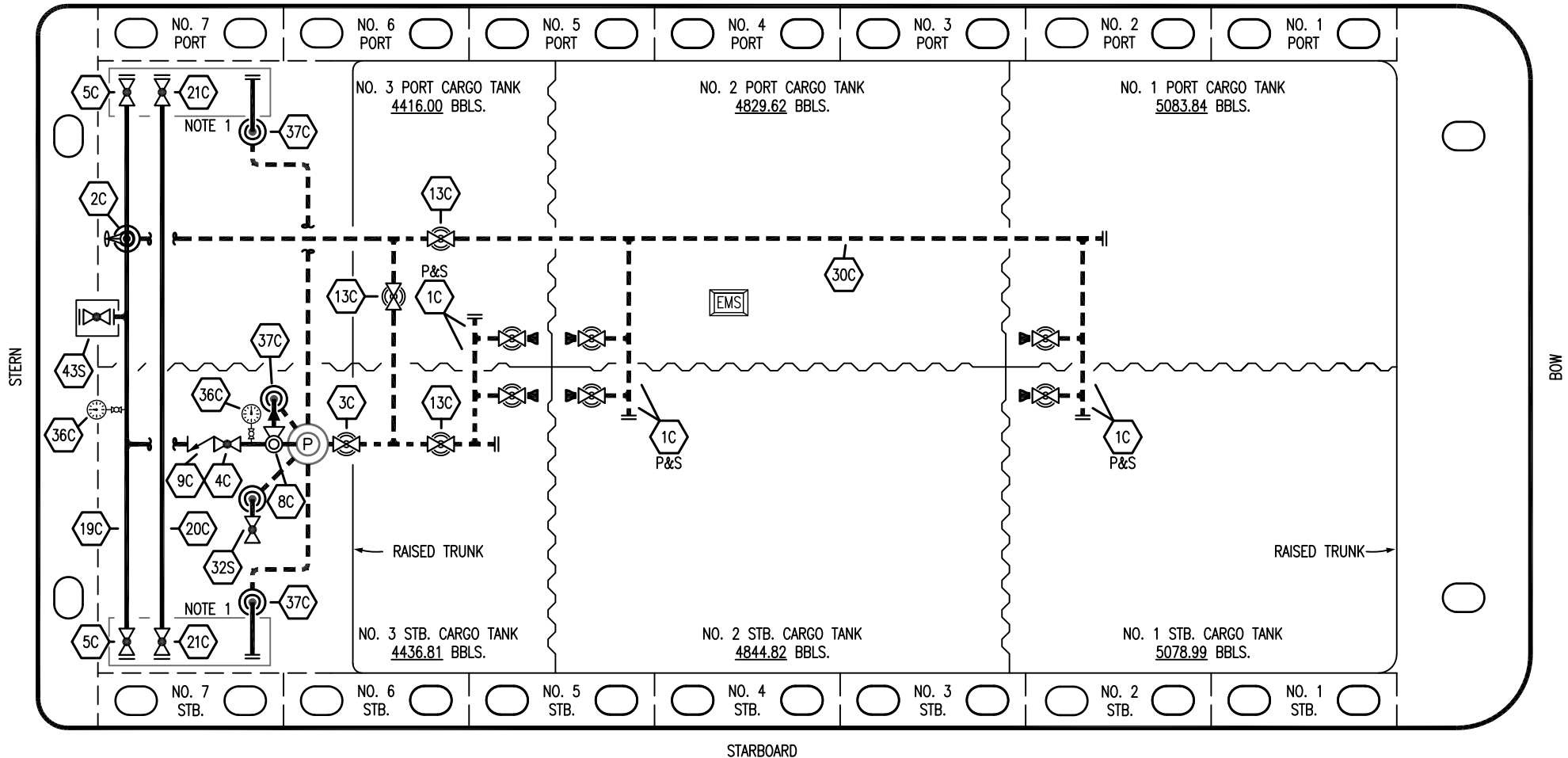

STARBOARD

NO	DESCRIPTION	NO	DESCRIPTION
1C	CARGO TANK VALVE	20C	DUMMY HEADER PIPING
2C	LOAD VALVE	21C	DUMMY HEADER VALVE
3C	MASTER SUCTION VALVE	30C	CARGO PIPELINE
4C	DISCHARGE VALVE	32S	DEEPWELL STRIPPING VALVE SUCTION
5C	HEADER VALVE	36C	PRESSURE GAUGE
8C	RELIEF VALVE	37C	CARGO DROP
9C	CHECK VALVE	43S	STERN HEADER VALVE
13C	CARGO PIPING BLOCK VALVE	---	ABOVE DECK PIPING
19C	CARGO HEADER	---	BELOW DECK PIPING

NOTE 1: CONTAINMENT P/S

REV.	DATE	BY	CHK	APP	REVISION DESCRIPTION
3	12/07/22	MRV	DDA	CW	REVISED PER CLIENT COMMENTS
2	11/11/19	NRB	DDA		REVISED PER CLIENT COMMENTS
1	10/01/19	NRB	DDA		REVISED BARGE NAME
0	02/20/19	MRV	DDA		ISSUED FOR APPROVAL

TRINITY

KIRBY INLAND MARINE

CARGO

PIPING FLOW DIAGRAM

KIRBY 27731

SCALE: NONE
PAGE: 1 OF 4

REV. 3

PORT

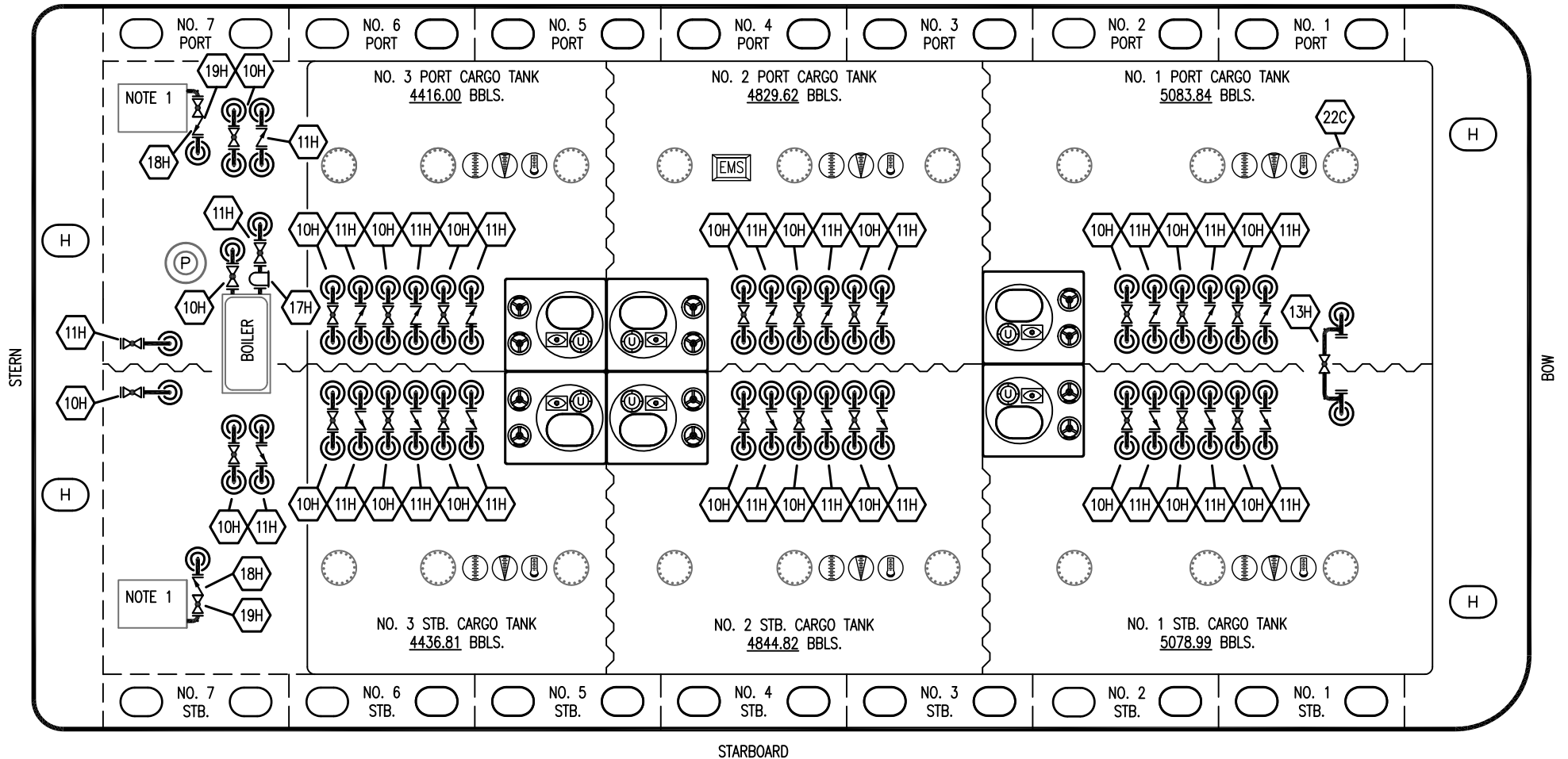

STARBOARD

- | NO | DESCRIPTION |
|---------------------|----------------------|
| 10H | SUPPLY VALVE |
| 11H | RETURN |
| 12H | PRESSURE REGULATOR |
| 13H | BY-PASS |
| 17H | BASKET STRAINER |
| 18H | CHECK VALVE |
| 19H | DRIP PAN DRAIN VALVE |
| — ABOVE DECK PIPING | |

NOTE 1: 6 BARREL DRIP PAN

TRINITY

REV.	DATE	BY	CHK	APP	REVISION DESCRIPTION
2	12/07/22	MRV	DDA	CW	REVISED PER CLIENT COMMENTS
1	10/01/19	NRB	DDA		REVISED BARGE NAME
0	02/20/19	MRV	DDA		ISSUED FOR APPROVAL

KIRBY INLAND MARINE 

**HOT OIL
PIPING FLOW DIAGRAM**

SCALE: NONE
PAGE: 2 of 4

KIRBY 27731

REV. **2**

PORT

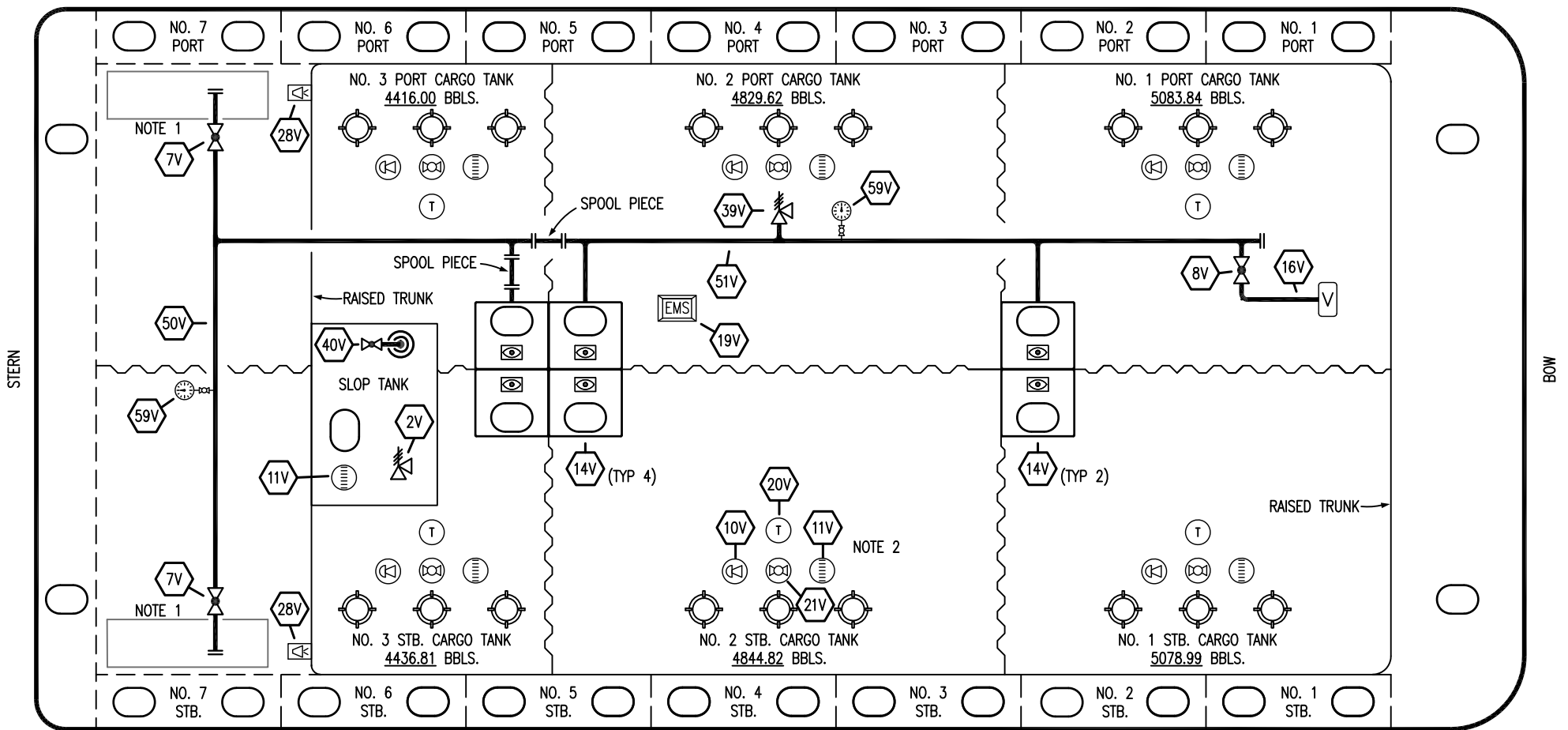

- | | |
|-----|----------------------------|
| NO | DESCRIPTION |
| 2V | PRESS/VAC SLOP TANK RELIEF |
| 7V | HEADER VALVE |
| 8V | VENT STACK VALVE |
| 10V | HIGH LEVEL/OVERFILL ALARM |
| 11V | 1-METER GAUGE STICK |
| 14V | SIGHT GLASS |
| 16V | VAPOR VENT STACK |
| 19V | EMERGENCY ENGINE SHUT DOWN |

- | | |
|-----|--|
| NO | DESCRIPTION |
| 20V | PORTABLE TEMPERATURE DISPLAY UNIT (PTDU) |
| 21V | HERMETIC GAUGE |
| 28V | DOCK CONNECTION ALARM |
| 39V | PRESSURE/VACUUM RELIEF VALVE |
| 40V | SLOP TANK SUCTION VALVE |
| 50V | VAPOR HEADER |
| 51V | VAPOR PIPELINE |
| 59V | PRESS/VAC GAUGE |
| — | ABOVE DECK PIPING |

STARBOARD

NOTE 2: TYPICAL RIGGING IN EACH TANK
NOTE 1: CONTAINMENT P/S

TRINITY

REV.	DATE	BY	CHK	APP	REVISION DESCRIPTION
2	12/07/22	MRV	DDA	CW	REVISED PER CLIENT COMMENTS
1	10/01/19	NRB	DDA		REVISED BARGE NAME
0	02/20/19	MRV	DDA		ISSUED FOR APPROVAL

KIRBY INLAND MARINE 

**VAPOR
PIPING FLOW DIAGRAM**

SCALE: NONE
PAGE: 3 OF 4

KIRBY 27731

REV. **2**

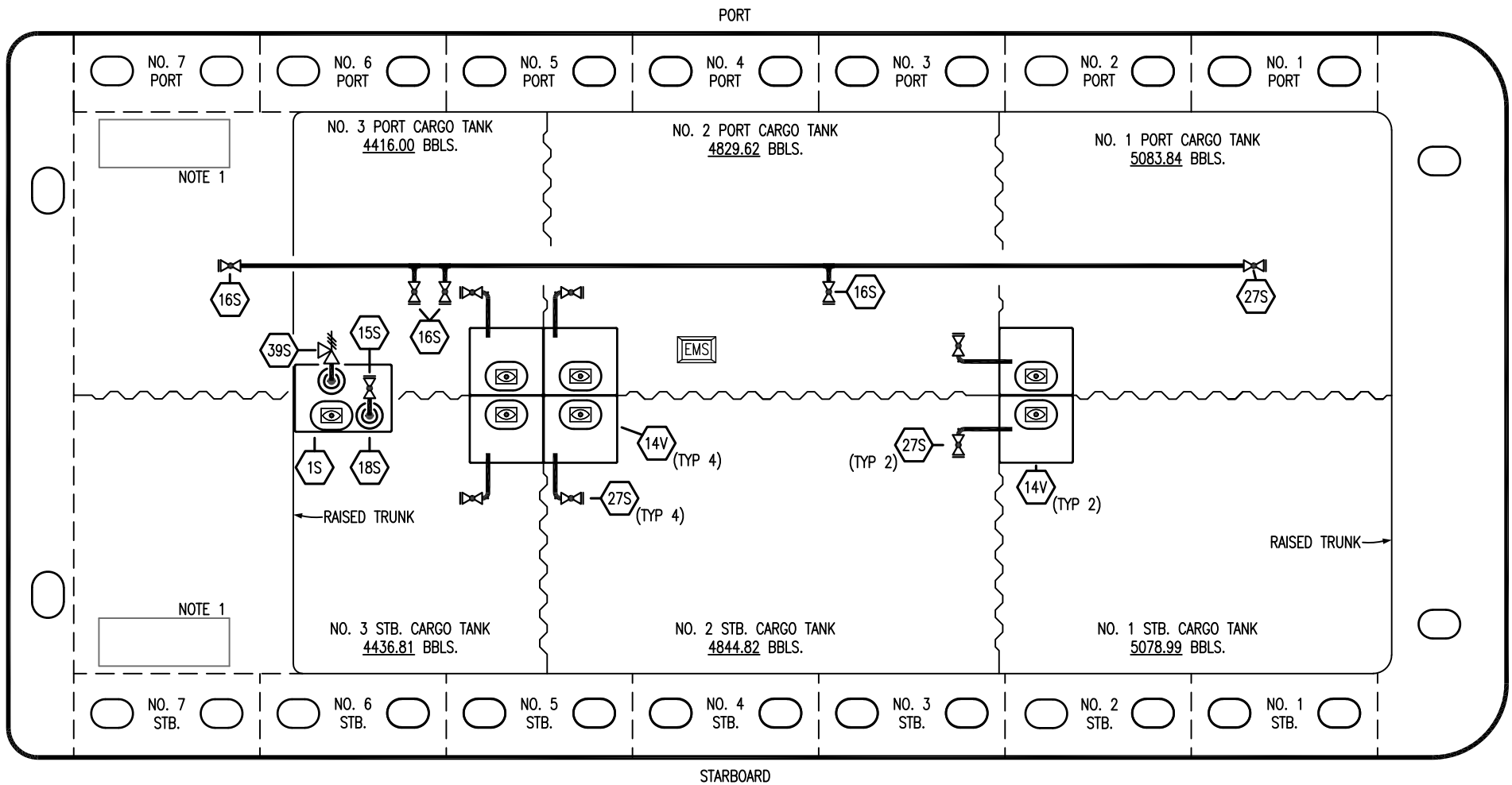

- | | | | |
|-----|--------------------------------|-------|-------------------|
| NO | DESCRIPTION | NO | DESCRIPTION |
| 1S | SLOP TANK | 36C | PRESSURE GAUGE |
| 2S | CARGO SUMP SUCTION VALVE | 39S | P/V VALVE |
| 14V | SIGHT GLASS | — | ABOVE DECK PIPING |
| 15S | DISCHARGE VALVE | - - - | BELOW DECK PIPING |
| 16S | REMOTE SUCTION CONNECTION | | |
| 18S | TYP. STRIPPING PENETRATION (⊙) | | |
| 19V | EMERGENCY ENGINE SHUT DOWN | | |
| 26S | STRIPPING HEADER BLOCK VALVE | | |
| 27S | SUMP SUCTION VALVE | | |

NOTE 1: CONTAINMENT P/S

REV.	DATE	BY	CHK	APP	REVISION DESCRIPTION
1	12/07/22	MRV	DDA	CW	REVISED PER CLIENT COMMENTS
0	10/01/19	NRB	DDA		ISSUED FOR APPROVAL



KIRBY INLAND MARINE

**STRIPPING
PIPING FLOW DIAGRAM**

KIRBY 27731

SCALE: NONE	REV 1
PAGE: 4 OF 4	