

PORT

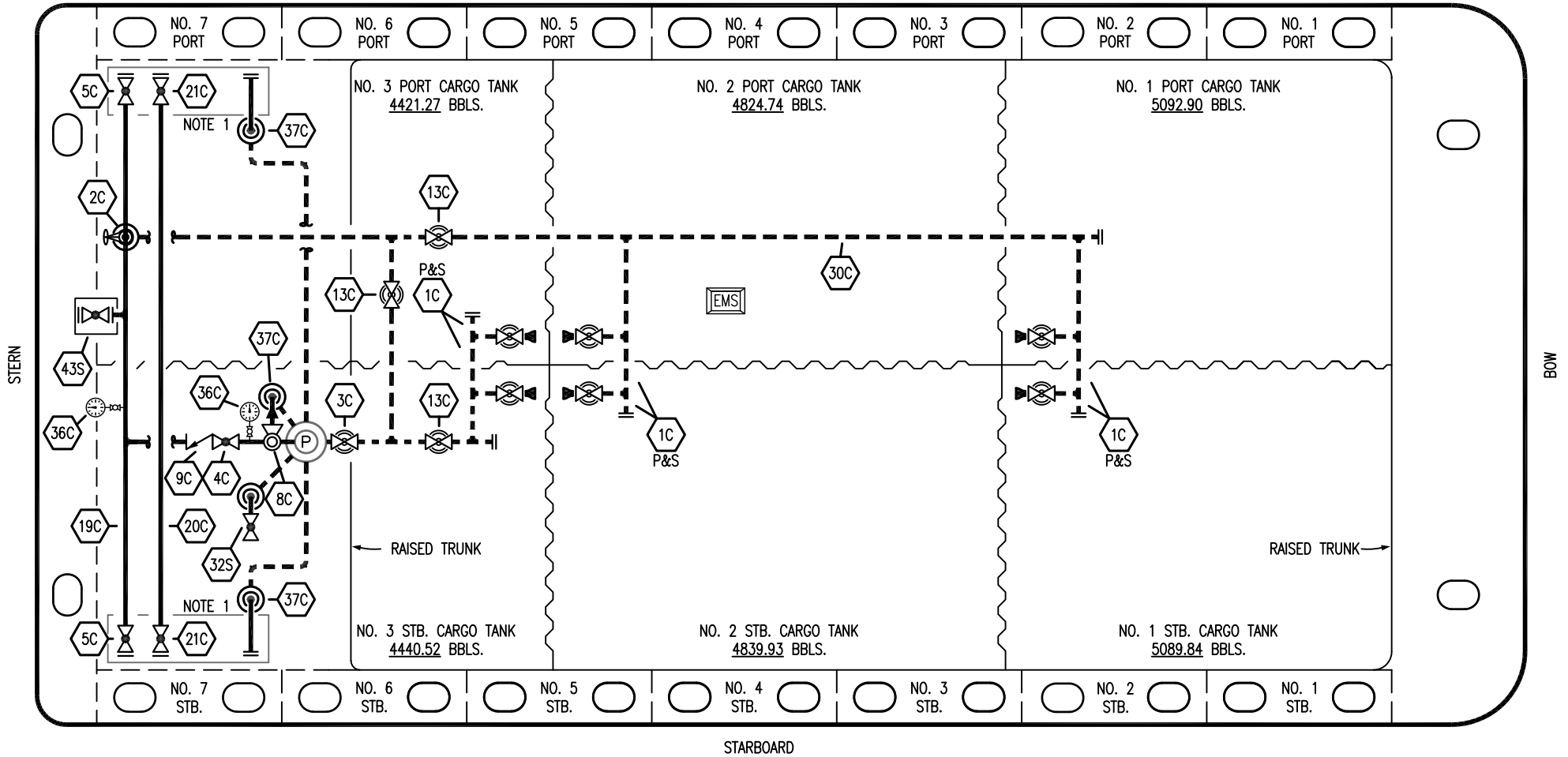

STARBOARD

NO	DESCRIPTION	NO	DESCRIPTION
1C	CARGO TANK VALVE	20C	DUMMY HEADER PIPING
2C	LOAD VALVE	21C	DUMMY HEADER VALVE
3C	MASTER SUCTION VALVE	30C	CARGO PIPELINE
4C	DISCHARGE VALVE	32S	DEEPWELL STRIPPING VALVE SUCTION
5C	HEADER VALVE	36C	PRESSURE GAUGE
8C	RELIEF VALVE	37C	CARGO DROP
9C	CHECK VALVE	43S	STERN HEADER VALVE
13C	CARGO PIPING BLOCK VALVE	—	— ABOVE DECK PIPING
19C	CARGO HEADER	- - -	- - - BELOW DECK PIPING

NOTE 1: CONTAINMENT P/S

REV.	DATE	BY	CHK	APP	REVISION DESCRIPTION
2	12/07/22	MRV	DDA	CW	REVISED PER CLIENT COMMENTS
1	11/12/19	NRB	DDA		REVISED PER CLIENT COMMENTS
0	06/04/19	MRV	DDA		ISSUED FOR APPROVAL

TRINITY

KIRBY INLAND MARINE

CARGO

PIPING FLOW DIAGRAM

KIRBY 27729	REV. 2
SCALE: NONE	PAGE: 1 OF 3

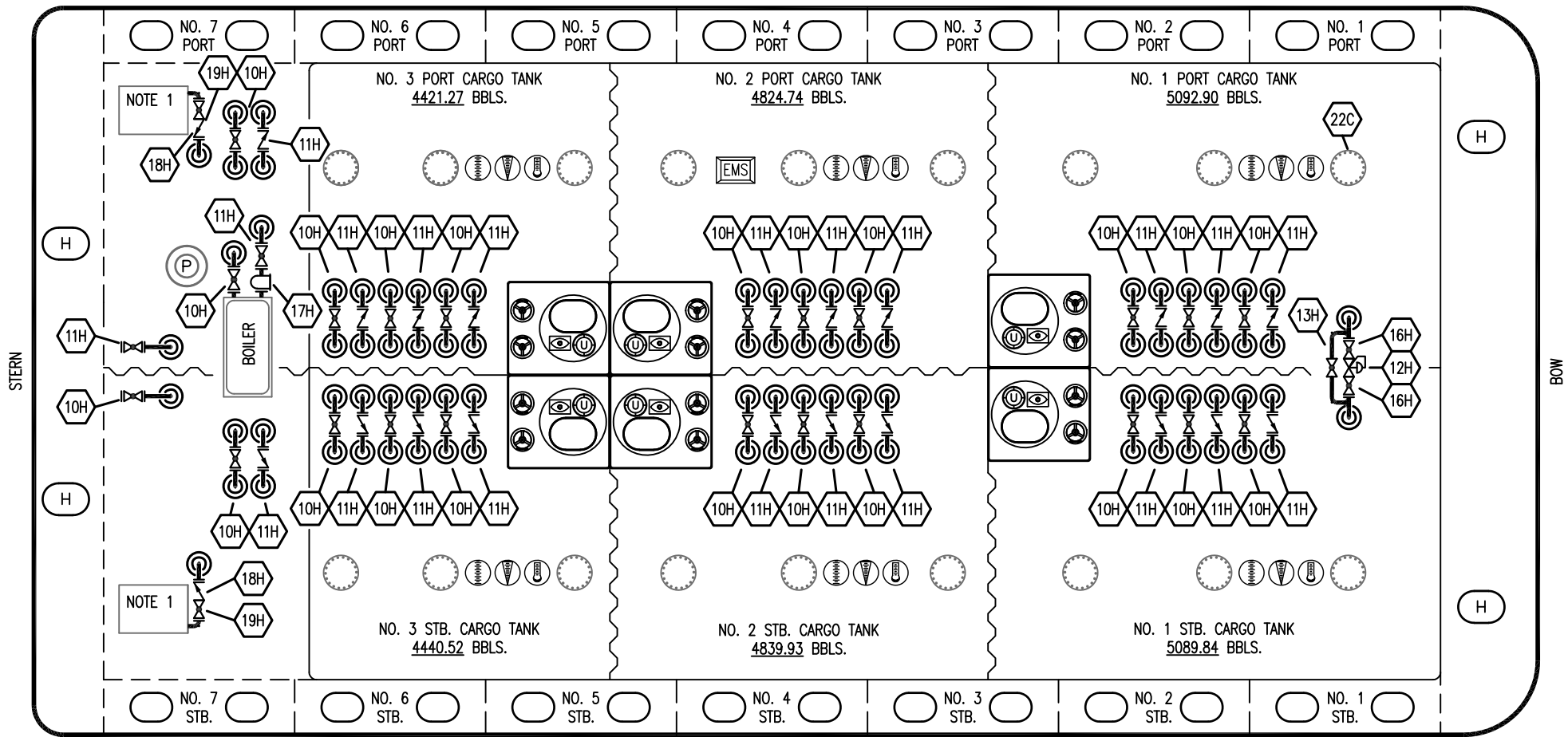

- | NO | DESCRIPTION |
|-----|----------------------|
| 10H | SUPPLY VALVE |
| 11H | RETURN |
| 12H | PRESSURE REGULATOR |
| 13H | BY-PASS |
| 16H | ISOLATION VALVE |
| 17H | BASKET STRAINER |
| 18H | CHECK VALVE |
| 19H | DRIP PAN DRAIN VALVE |
- ABOVE DECK PIPING

NOTE 1: 6 BARREL DRIP PAN

REV.	DATE	BY	CHK	APP	REVISION DESCRIPTION
1	12/07/22	MRV	DDA	CW	REVISED PER CLIENT COMMENTS
0	06/04/19	MRV	DDA		ISSUED FOR APPROVAL

TRINITY

KIRBY INLAND MARINE

**HOT OIL
PIPING FLOW DIAGRAM**

KIRBY 27729

SCALE: NONE	REV. 1
PAGE: 2 of 3	

PORT

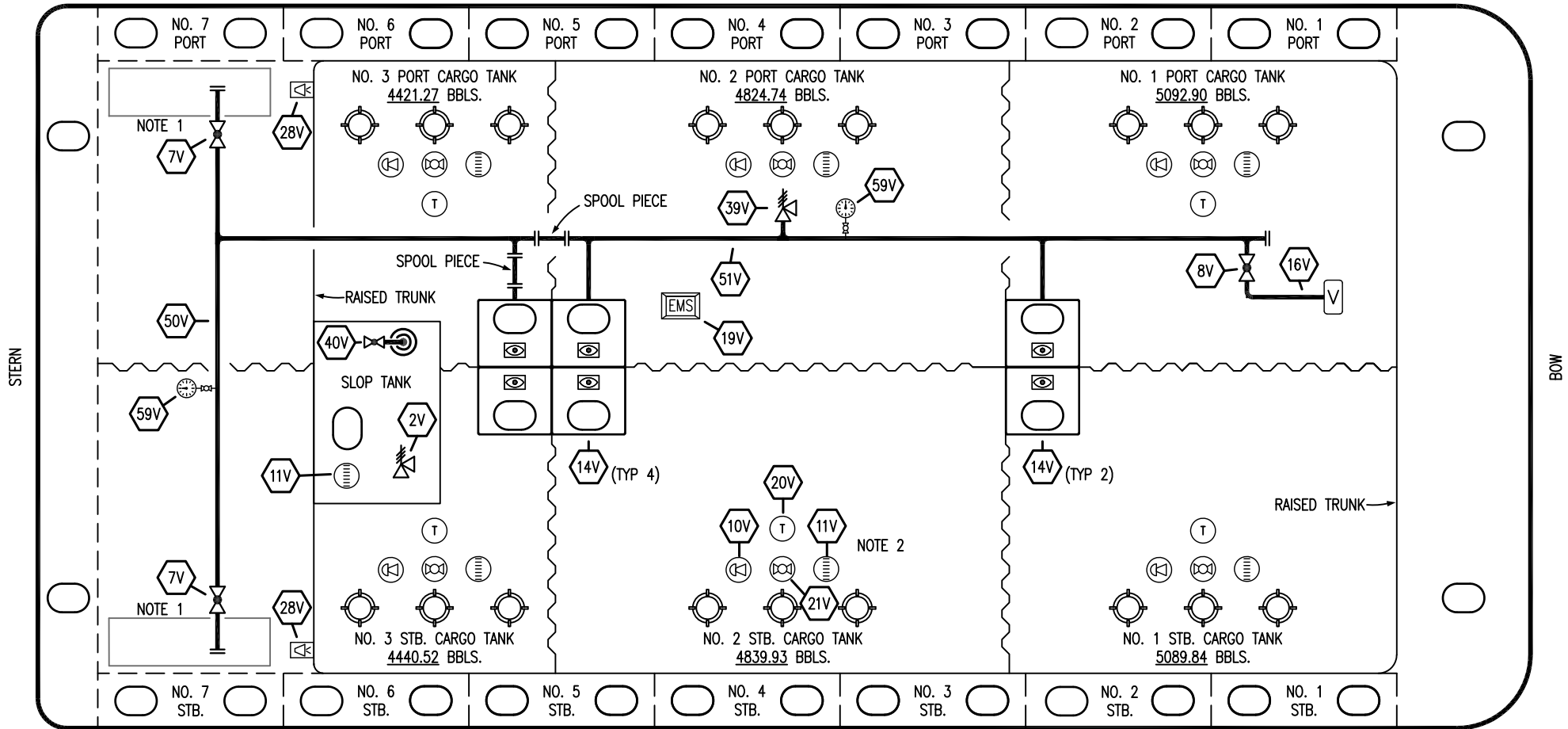

- | | |
|-----|----------------------------|
| NO | DESCRIPTION |
| 2V | PRESS/VAC SLOP TANK RELIEF |
| 7V | HEADER VALVE |
| 8V | VENT STACK VALVE |
| 10V | HIGH LEVEL/OVERFILL ALARM |
| 11V | 1-METER GAUGE STICK |
| 14V | SIGHT GLASS |
| 16V | VAPOR VENT STACK |
| 19V | EMERGENCY ENGINE SHUT DOWN |

- | | |
|-----|--|
| NO | DESCRIPTION |
| 20V | PORTABLE TEMPERATURE DISPLAY UNIT (PTDU) |
| 21V | HERMETIC GAUGE |
| 28V | DOCK CONNECTION ALARM |
| 39V | PRESSURE/VACUUM RELIEF VALVE |
| 40V | SLOP TANK SUCTION VALVE |
| 50V | VAPOR HEADER |
| 51V | VAPOR PIPELINE |
| 59V | PRESS/VAC GAUGE |
| — | ABOVE DECK PIPING |

NOTE 2: TYPICAL RIGGING IN EACH TANK
NOTE 1: CONTAINMENT P/S

REV.	DATE	BY	CHK	APP	REVISION DESCRIPTION
1	12/07/22	MRV	DDA	CW	REVISED PER CLIENT COMMENTS
0	06/04/19	MRV	DDA		ISSUED FOR APPROVAL

KIRBY INLAND MARINE 

**VAPOR
PIPING FLOW DIAGRAM**

TRINITY