

PORT

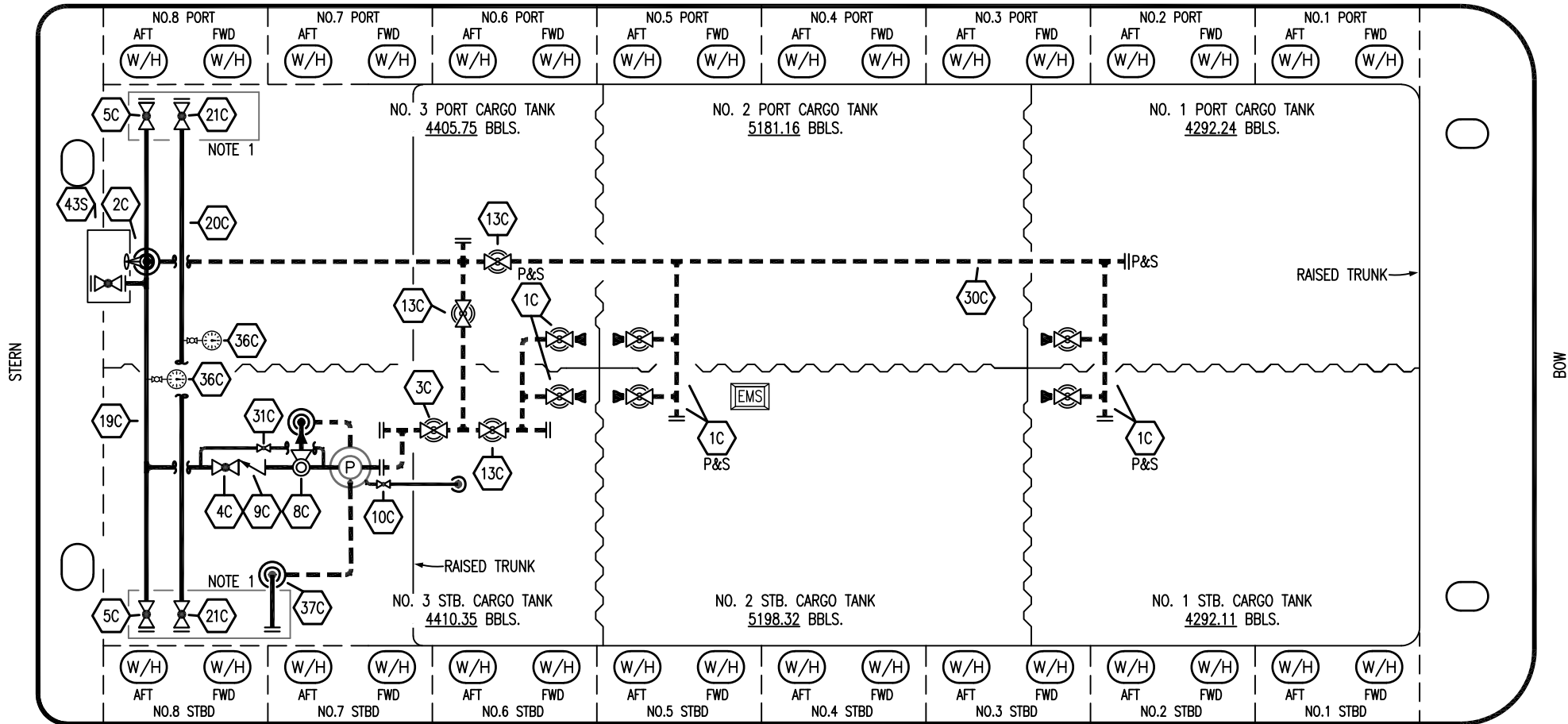

STARBOARD

NO	DESCRIPTION	NO	DESCRIPTION
1C	CARGO TANK VALVE	20C	DUMMY HEADER PIPING
2C	LOAD VALVE	21C	DUMMY HEADER VALVE
3C	MASTER SUCTION VALVE	30C	CARGO PIPELINE
4C	DISCHARGE VALVE	31C	BYPASS VALVE
5C	HEADER VALVE	36C	PRESSURE GAUGE
6C	SALVAGE VALVE	37C	CARGO DROP
8C	RELIEF VALVE	43S	STERN HEADER VALVE
9C	CHECK VALVE	—	— ABOVE DECK PIPING
10C	BURP VALVE	---	--- BELOW DECK PIPING
13C	CARGO PIPING BLOCK VALVE		
19C	CARGO HEADER		

NOTE 1: CONTAINMENT P/S

TRINITY MARINE — EX CTCO 354

REV.	DATE	BY	CHK	APP	REVISION DESCRIPTION
1	07/01/24	MRV	DDA	LEP	REVISED PER CLIENT COMMENTS
0	06/04/19	MRV	DDA		ISSUED FOR APPROVAL

**KIRBY INLAND MARINE**

**CARGO  
PIPING FLOW DIAGRAM**

SCALE: NONE  
PAGE: 1 OF 3

**KIRBY 27014**

REV. **1**

PORT

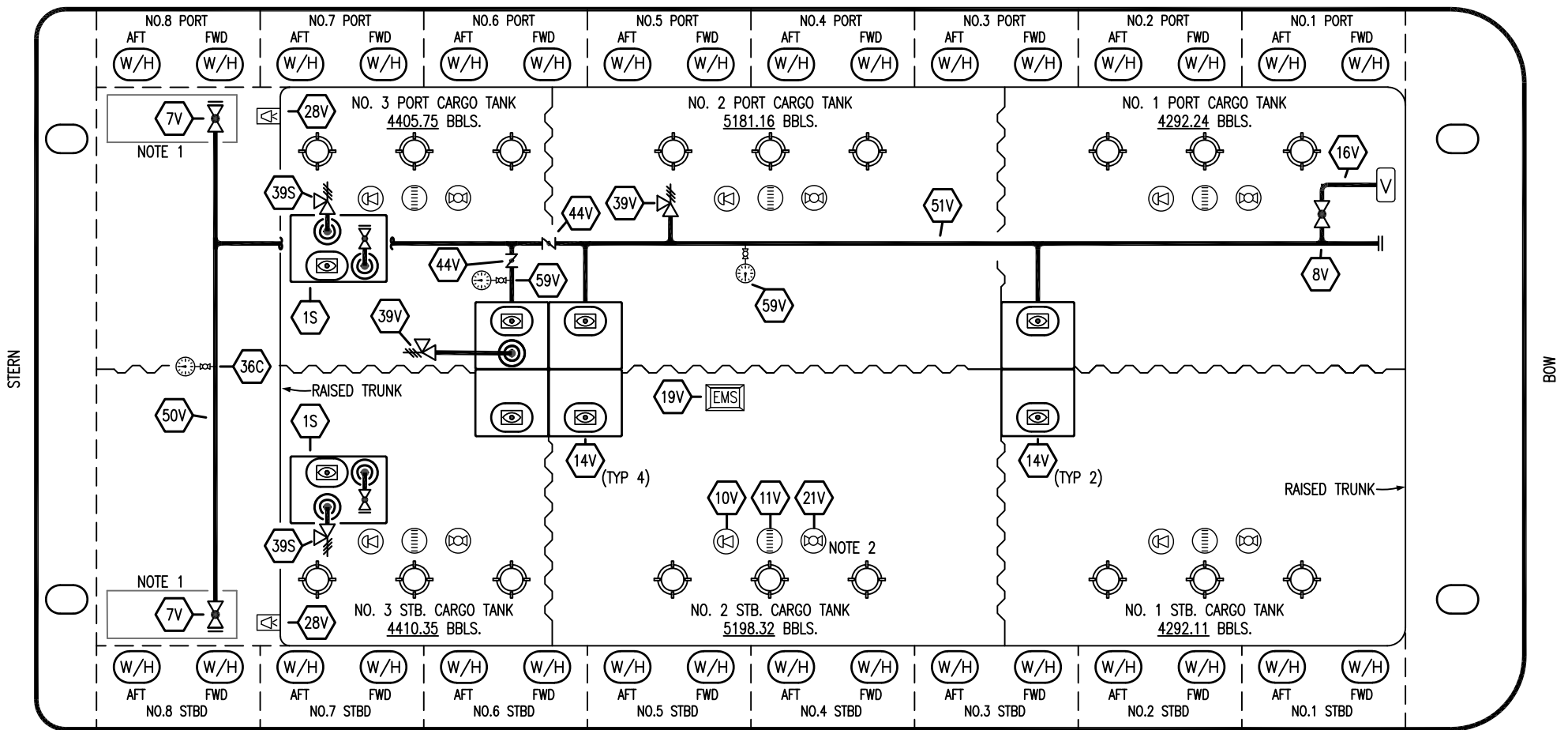

STARBOARD

NO	DESCRIPTION	NO	DESCRIPTION
1S	SLOP TANK	28V	DOCK CONNECTION ALARM
7V	8" HEADER VALVE	36C	PRESSURE GAUGE
8V	8" VENT STACK VALVE	38V	8" VAPOR PENETRATION
10V	HIGH LEVEL/OVERFILL ALARM	39S	P/V VALVE
11V	1-METER GAUGE STICK	44V	BUTTERFLY VALVE
14V	SIGHT GLASS	50V	8" VAPOR HEADER
16V	VAPOR VENT STACK	51V	8" VAPOR PIPELINE
19V	EMERGENCY ENGINE SHUT DOWN	59V	PRESS/VAC GAUGE
21V	2" HERMETIC GAUGE	—	ABOVE DECK PIPING

NOTE 2: TYPICAL RIGGING IN EACH TANK  
 NOTE 1: CONTAINMENT P/S

TRINITY MARINE — EX CTCO 354

REV.	DATE	BY	CHK	APP	REVISION DESCRIPTION
1	07/01/24	MRV	DDA	LEP	REVISED PER CLIENT COMMENTS
0	06/04/19	MRV	DDA		ISSUED FOR APPROVAL

KIRBY INLAND MARINE

VAPOR  
PIPING FLOW DIAGRAM

SCALE: NONE	KIRBY 27014
PAGE: 2 OF 3	1

PORT

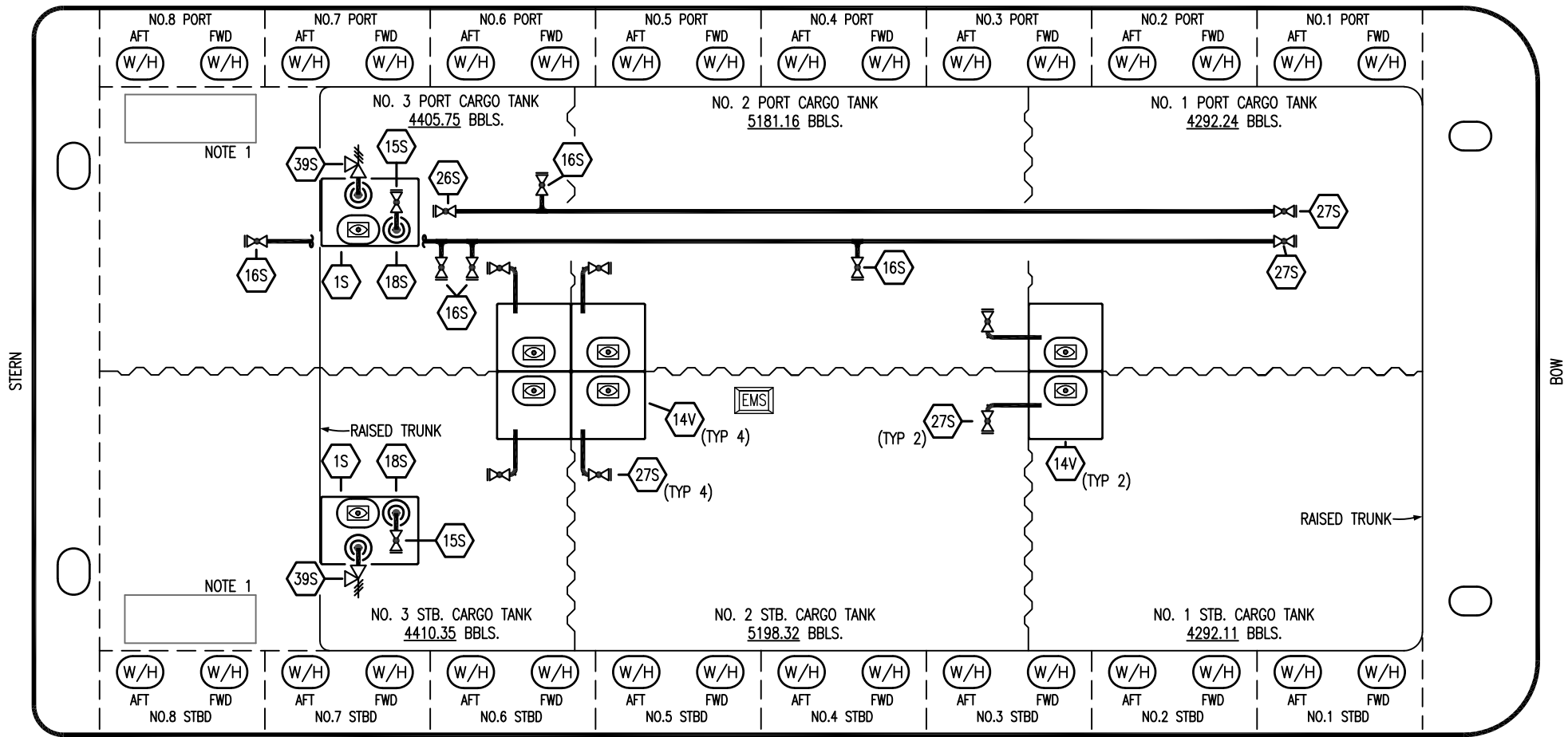

STARBOARD

- |     |                              |       |                   |
|-----|------------------------------|-------|-------------------|
| NO  | DESCRIPTION                  | NO    | DESCRIPTION       |
| 1S  | SLOP TANK                    | 36C   | PRESSURE GAUGE    |
| 2S  | CARGO SUMP SUCTION VALVE     | 39S   | P/V VALVE         |
| 14V | SIGHT GLASS                  | —     | ABOVE DECK PIPING |
| 15S | DISCHARGE VALVE              | - - - | BELOW DECK PIPING |
| 16S | REMOTE SUCTION CONNECTION    |       |                   |
| 18S | TYP. STRIPPING PENETRATION   |       |                   |
| 19V | EMERGENCY ENGINE SHUT DOWN   |       |                   |
| 26S | STRIPPING HEADER BLOCK VALVE |       |                   |
| 27S | SUMP SUCTION VALVE           |       |                   |

NOTE 1: CONTAINMENT P/S

TRINITY MARINE — EX CTCO 354

REV.	DATE	BY	CHK	APP	REVISION DESCRIPTION
1	07/01/24	MRV	DDA	LEP	REVISED PER CLIENT COMMENTS
0	06/04/19	MRV	DDA		ISSUED FOR APPROVAL



**KIRBY INLAND MARINE**

**STRIPPING**

**PIPING FLOW DIAGRAM**

**KIRBY 27014**

SCALE: NONE	REV 1
PAGE: 3 OF 3	