

NO	DESCRIPTION	NO	DESCRIPTION
1C	8" CARGO TANK VALVE	13C	10" CARGO PIPING BLOCK VALVE
2C	8" LOAD VALVE	19C	8" CARGO HEADER
3C	10" MASTER SUCTION VALVE	30C	10" CARGO PIPELINE
4C	6" DISCHARGE VALVE	31C	2" BYPASS VALVE
5C	8" HEADER VALVE	35S	2" STRIPPING VALVE
8C	6" RELIEF VALVE	37C	CARGO DROP 
9C	8" CHECK VALVE	—	— ABOVE DECK PIPING
		- - -	BELOW DECK PIPING

NOTE 1: CONTAINMENT P/S

REV.	DATE	BY	CHK	APP	REVISION DESCRIPTION
1	01/27/23	MRV	DDA	KW	REVISED PER CLIENT COMMENTS
0	11/19/18	MRV	DDA		ISSUED FOR APPROVAL

KIRBY INLAND MARINE 

**CARGO
PIPING FLOW DIAGRAM**

SCALE: NONE
PAGE: 1 OF 2

KIRBY 11333

REV. **1**

EX. CGBM 106

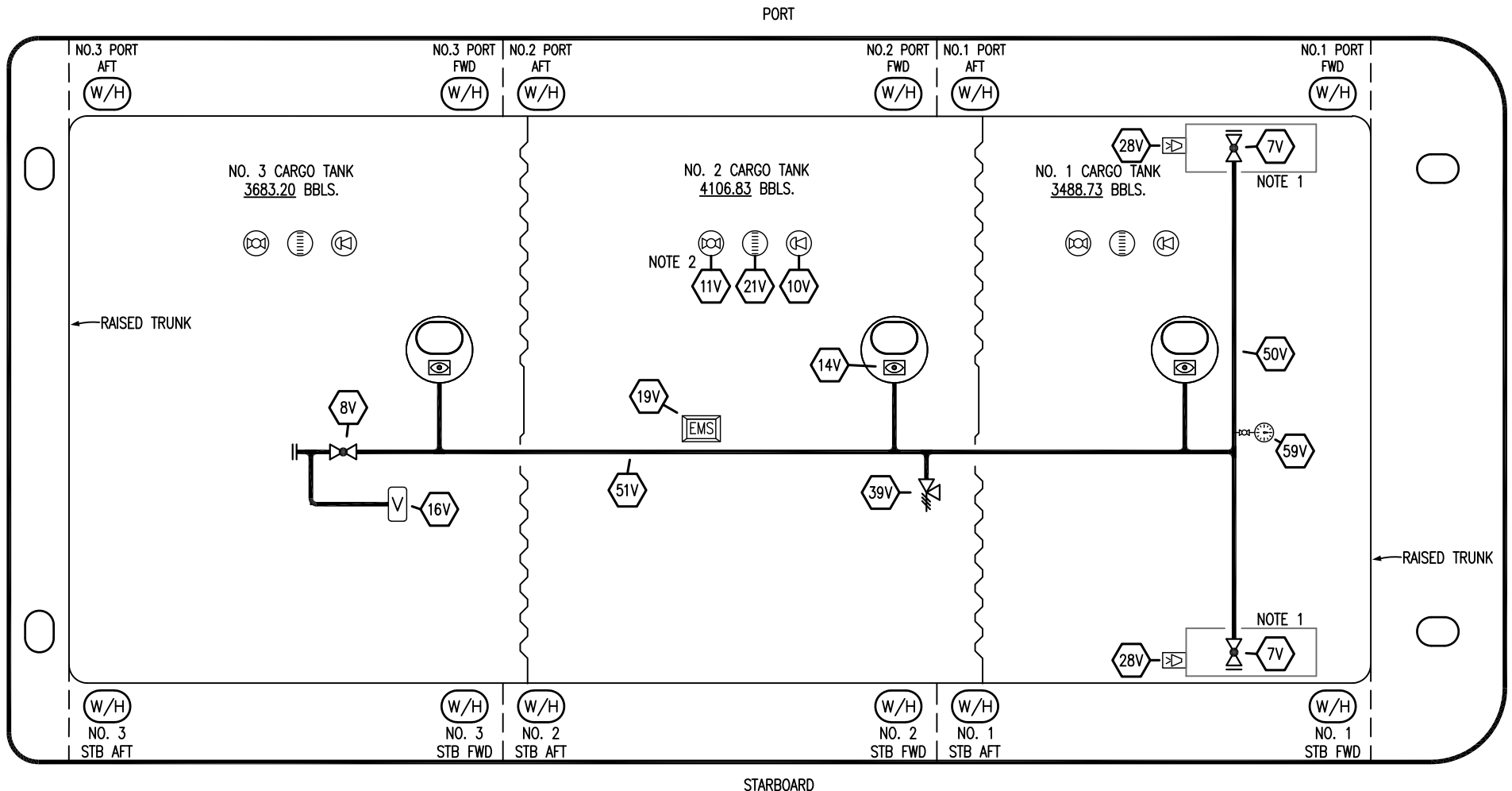

- | | | | |
|-----|----------------------------|-----|-----------------------|
| NO | DESCRIPTION | NO | DESCRIPTION |
| 7V | 8" HEADER VALVE | 28V | DOCK CONNECTION ALARM |
| 8V | 8" VENT STACK VALVE | 39V | PRESSURE/VACUUM VALVE |
| 10V | HIGH LEVEL/OVERFILL ALARM | 50V | 8" VAPOR HEADER |
| 11V | 1-METER GAUGE STICK | 51V | 8" VAPOR PIPELINE |
| 14V | SIGHT GLASS | 59V | PRESS/VAC GAUGE |
| 16V | VAPOR VENT STACK | — | ABOVE DECK PIPING |
| 19V | EMERGENCY ENGINE SHUT DOWN | | |
| 21V | 2" HERMETIC GAUGE | | |

NOTE 2: TYPICAL RIGGING IN EACH TANK
 NOTE 1: CONTAINMENT P/S

EX. CGBM 106

REV.	DATE	BY	CHK	APP	REVISION DESCRIPTION
1	01/27/23	MRV	DDA	KW	REVISED PER CLIENT COMMENTS
0	11/19/18	MRV	DDA		ISSUED FOR APPROVAL



KIRBY INLAND MARINE

VAPOR PIPING FLOW DIAGRAM

KIRBY 11333

SCALE: NONE	REV. 1
PAGE: 2 OF 2	