

PORT

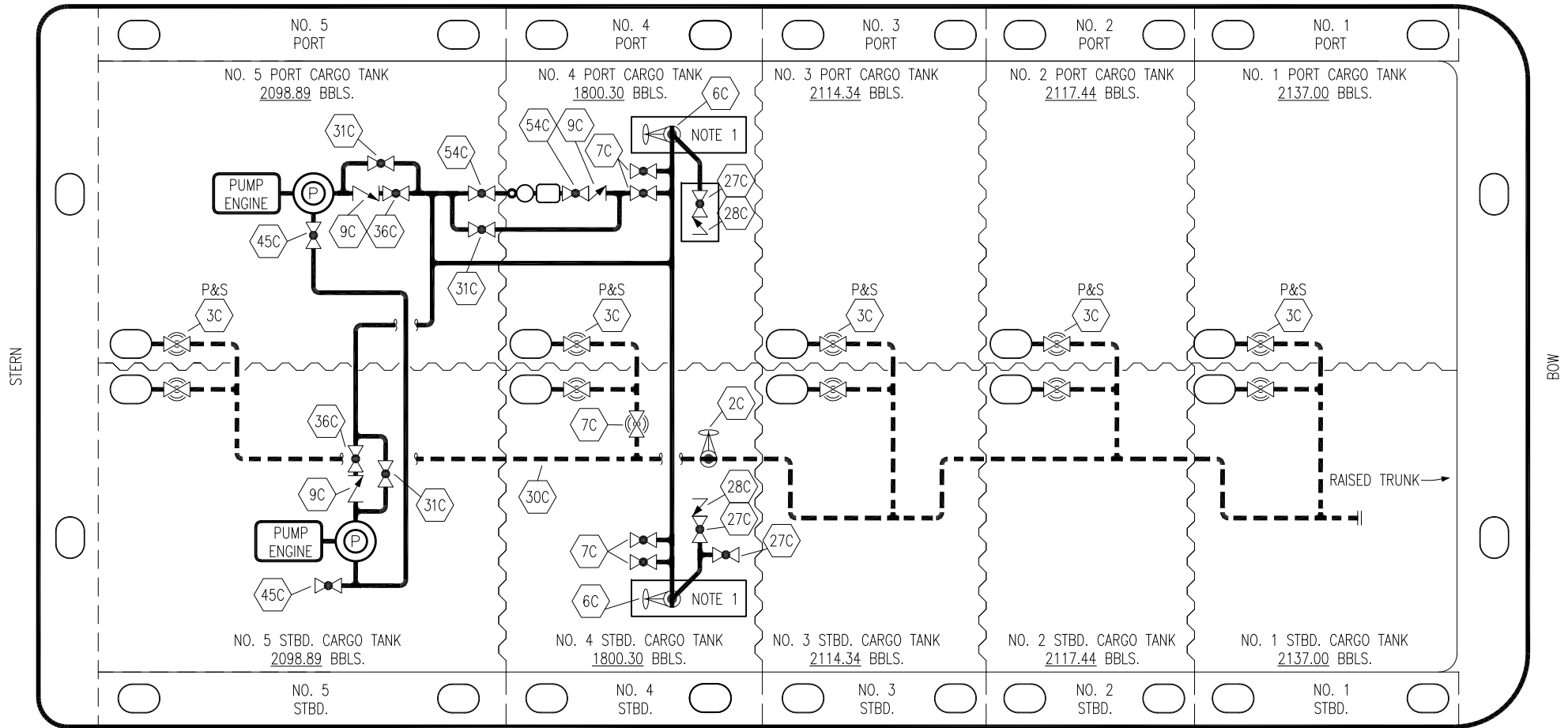

STARBOARD

NO	DESCRIPTION	NO	DESCRIPTION
2C	LOAD VALVE	28C	DRIP PAN CHECK VALVE
3C	SUCTION VALVE	31C	BYPASS VALVE
4C	DISCHARGE VALVE	36C	PUMP DISCHARGE VALVE
6C	TRANSVERSE HEADER VALVE	45C	PUMP SUCTION VALVE
7C	TRANSVERSE HEADER BRANCH VALVE	54C	DISCHARGE METER VALVE
9C	CHECK VALVE	—	— ABOVE DECK PIPING
27C	DRIP PAN VALVE	---	--- BELOW DECK PIPING

NOTE 1: CONTAINMENT P/S

TRINITY MARINE -- EX: N/A

REV.	DATE	BY	CHK	APP	REVISION DESCRIPTION
0	07/05/22	MRV	DDA	WHI	REVISED PER CLIENT COMMENTS

KIRBY INLAND MARINE 

**CARGO
PIPING FLOW DIAGRAM**

SCALE: NONE
PAGE: 1 OF 1

401

REV. **0**